

CONSTRUCTIONS IN ELLIPTIC DYNAMICS.

BASSAM FAYAD, ANATOLE KATOK*

ABSTRACT. We present an overview and some new applications of the approximation by conjugation method introduced by Anosov and the second author more than thirty years ago [1]. Michel Herman made important contributions to the development and applications of this method beginning from the construction of minimal and uniquely ergodic diffeomorphisms jointly with Fathi in [5] and continuing with exotic invariant sets of rational maps of the Riemann sphere [19], and the construction of invariant tori with nonstandard and unexpected behavior in the context of KAM theory [20, 21]. Recently the method has been experiencing a revival. Some of the new results presented in the paper illustrate variety of uses for tools available for a long time, others exploit new methods, in particular possibility of mixing in the context of Liouvillean dynamics discovered by the first author [6, 7].

1. ELLIPTIC DYNAMICS. DIOPHANTINE AND LIOUVILLEAN BEHAVIOR

In this paper we present and discuss a variety of examples of C^∞ volume preserving diffeomorphisms of compact manifolds which by any reasonable count should be viewed as exotic if not pathological. The methods which produce those examples are discussed in the next section and specific constructions carried out in the rest of the paper. Before doing that we would like to present a brief justification for paying attention to these admittedly very special situations by putting them into a certain general perspective along the lines of [16, Section 7], where a more detailed discussion and appropriate references can be found.

The term “elliptic dynamics” is often, although not universally, used to denote the study of recurrent (conservative) behavior in dynamical systems at the other end of the spectrum from “chaotic”. While in the everyday usage the opposite of “chaotic” would be “ordered”, in the dynamics context the preferred counterpart is “stable”. The stable asymptotic behavior in the context of conservative motions is best represented by quasiperiodic motions (translations and linear flows) on tori, which appear for example in completely integrable Hamiltonian systems. Such a system splits on most of its phase space into invariant tori which are determined by the fixed values of the action integrals in the action–angle coordinates. On each torus the motion is linear in the angle coordinates with the frequency vector determined by the action vector (see [26, Section 1.5] for an introductory discussion). It

*) Partially supported by NSF grant DMS-0071339.

is quite remarkable that under a suitable nondegeneracy assumption many (in fact, most in terms of phase volume) invariant tori survive slightly distorted under any small Hamiltonian perturbation of the system. This is the principal content of KAM theory to which Michel Herman made major contributions [18]. This prevalence of stability which also appears in other contexts (see e.g. [17]) is of course a major manifestation of elliptic phenomena.

Stability appears when the linear model, the translation (or rotation if multiplicative notations are used) of the torus \mathbb{T}^k ,

$$T_\alpha x = x + \alpha, \quad \text{mod } 1$$

or the linear flow on \mathbb{T}^k ,

$$T_\omega^t x = x + \omega t, \quad \text{mod } 1, \quad t \in \mathbb{R}$$

is of a *Diophantine* type, i.e. the translation vector α or the frequency vector ω is not too well approximated by rationals. A typical Diophantine condition in the discrete-time case is

$$|\langle \alpha, m \rangle - n| > C \|m\|^{-s}$$

for any $m \in \mathbb{Z}^k$, $n \in \mathbb{Z}$ and some positive numbers C and s independent of m and n . Similarly in the continuous-time case one has for some positive C and s and any $m \in \mathbb{Z}^k$,

$$|\langle \omega, m \rangle| > C \|m\|^{-s}.$$

The opposite case of exceptionally good rational approximation of α or ω is usually called *Liouvillean*. The Liouvillean behavior is associated with instability: circle diffeomorphisms with Liouvillean rotation numbers usually have singular invariant measures and hence are conjugate to the corresponding rotations via nondifferentiable continuous maps, time-changes of linear flows of tori with Liouvillean frequency vectors often and in fact typically exhibit unexpected ergodic properties [8], the invariant tori of completely integrable Hamiltonian systems with Liouvillean frequency vectors usually do not survive after perturbations (or may survive with greatly distorted dynamics, see [20]).

This leads to another possible opposite to the chaotic behavior. Since the latter is associated with exponential growth of orbit complexity with time (positive entropy, exponential growth of the number of periodic orbits, etc; see e.g. [16, Section 6]) one may consider slow growth of various characteristics of such complexity as a hallmark of elliptic dynamics. Notice that translations and linear flows of a torus are isometries, hence there is no divergence of orbits, and in a certain sense no growth of orbit complexity with time at all. In the Diophantine case this behavior is often stable under small perturbations of the system while in the Liouvillean case perturbations of the linear models often produce substantive qualitative effects but only after long periods of time. To understand what kind of effects may result from this instability a constructive approach is quite useful. While

there is no chance to describe all possible effects which appear in nonlinear perturbations of Liouvillean behavior, the variety of possibilities is astonishing. In a number of cases such perturbations provide the only known way to exhibit certain types of dynamical behavior, e.g. ergodic behavior accompanied by only finitely many periodic points on such simple manifolds as the two-dimensional disc or two-dimensional sphere. See Section 3.1 for a more detailed discussion of those cases.

We would like to thank A. Fathi for pointing out to the paper [15] where a construction similar to those of Section 4 is carried out, M. Handel for valuable comments and observations which helped us to improve presentation in that section, A. Windsor and M. Saprykina for useful discussions.

2. AN OVERVIEW OF THE APPROXIMATION BY CONJUGATION METHOD

2.1. General scheme. Let M be a differentiable manifold with a nontrivial smooth circle action $\mathcal{S} = \{S_t\}_{t \in \mathbb{R}}$, $S_{t+1} = S_t$ preserving a smooth volume. Every smooth S^1 action preserves a smooth volume ν which can be obtained by taking any volume μ and averaging it with respect to the action: $\nu = \int_0^1 (S_t)_* \mu dt$. Similarly \mathcal{S} preserves a smooth Riemannian metric on M obtained by averaging of a smooth Riemannian metric.

When this does not cause an ambiguity we will often call the elements S_α of the circle action \mathcal{S} "rotations", correspondingly "rational" and "irrational", for rational or irrational values of α .

Denote by C_q the subgroup of S^1 with q elements, i.e the q th roots of unity. Assuming without loss of generality that the action is effective (no element acts as identity) we see that for an open dense subset of M the stationary subgroup is trivial. Using the standard properties of isometries one sees the set F of fixed points of the action is a smooth submanifold of M . The fixed point set F_q of the map $S_{\frac{1}{q}}$ (or, equivalently, of the action of C_q) is also a smooth submanifold.

Volume preserving maps with various interesting, often surprising, topological and ergodic properties are obtained as limits of volume preserving periodic transformations

$$f = \lim_{n \rightarrow \infty} f_n, \quad \text{where } f_n = H_n S_{\alpha_{n+1}} H_n^{-1} \quad (2.1)$$

with $\alpha_n = \frac{p_n}{q_n} \in \mathbb{Q}$ and

$$H_n = h_1 \circ \dots \circ h_n, \quad (2.2)$$

where every h_n is a volume preserving diffeomorphism of M that satisfies

$$h_n \circ S_{\alpha_n} = S_{\alpha_n} \circ h_n. \quad (2.3)$$

In certain versions of the method the diffeomorphisms h_n are chosen not preserving the volume but distorting it in a controllable way; this for example

is the only interesting situation when M is the circle (see e.g. [26, Section 12.6]).

Usually at step n , the diffeomorphism h_n is constructed first, and α_{n+1} is chosen afterwards close enough to α_n to guarantee convergence of the construction. For example, it is easy to see that for the limit in (2.1) to exist in the C^∞ topology it is sufficient to ask that

$$|\alpha_{n+1} - \alpha_n| \leq \frac{1}{2^n \|H_n\|_{C^n}}. \quad (2.4)$$

The power and fruitfulness of the method depend on the fact that the sequence of diffeomorphisms f_n is made to converge while the conjugacies H_n diverge often “wildly” albeit in a controlled (or prescribed) way. Dynamics of the circle actions and of their individual elements is simple and well-understood. In particular, no element of such an action is ergodic or topologically transitive, unless the circle action itself is transitive, i.e. $M = S^1$. To provide interesting asymptotic properties of the limit typically the successive conjugacies spread the orbits of the circle action \mathcal{S} (and hence also those of its restriction to the subgroup C_q for any sufficiently large q) across the phase space M making them almost dense, or almost uniformly distributed, or approximate another type of interesting asymptotic behavior. Due to the high speed of convergence this remains true for sufficiently long orbit segments of the limit diffeomorphism. To guarantee an appropriate speed of approximation extra conditions on convergence of approximations in addition to (2.4) may be required.

There are many variations of the construction within this general scheme. In the subsequent sections we describe several representative versions, each addressing a problem which has not been treated before. Presenting each version to the last detail and in the greatest generality would be quite tedious. Accordingly we often choose to describe routine steps only briefly and sometimes treat representative special cases indicating generalizations afterwards.

2.2. Almost all vs. all orbits. In different versions of the approximation by conjugation method one may control the asymptotic behavior of almost all orbits with respect to the invariant volume, or of all orbits. Somewhat imprecisely we will call those versions ergodic and topological.

Ergodic constructions deal with measure-theoretic (ergodic) properties with respect to a given invariant volume, such as the number of ergodic components (in particular ergodicity), rigidity, weak mixing, mixing, further spectral properties. Topological constructions deal with minimality, number of ergodic invariant measures (e.g. unique ergodicity) and their supports, presence of particular invariant sets, and so on. The paper [1] dealt only with ergodic constructions. A topological version was announced in [22] (see also [3]) and independently developed in [5].

Control over behavior of the orbits of approximating periodic diffeomorphisms f_n in (2.1) on the n th step of the construction is typically provided

by taking an invariant under S_{α_n} (and hence under $S_{\perp}^{q_n}$) collection of "kernels", usually smooth balls, and redistributing them in the phase space in a prescribed fashion (also $S_{\perp}^{q_n}$ invariant). In ergodic constructions one requires the complement to the union of the kernels to have small volume and hence most orbits of \mathcal{S} (and consequently of any finite subgroup C_q for a sufficiently large q) to spend most of the time inside the kernels. In the topological versions the kernels need to be chosen in such a way that *every* orbit of \mathcal{S} spends most of the time inside the kernels. This requires more care and certain attention to the geometry of orbits. See for example Figures 3.1 and 3.2.

A natural way of selecting the kernels, their intended images, and constructing a map h_n satisfying (2.3) is by taking a fundamental domain Δ for S_{α_n} (or, equivalently, for $S_{\perp}^{q_n}$) choosing kernels and images inside Δ , constructing a diffeomorphism of Δ to itself identical near its boundary which sends kernels into their intended images, and extending the map to the images $S_{\perp}^{q_n, k}$, $k = 1, \dots, q_n - 1$ by commutativity. This method in particular is used in the construction of a diffeomorphism conjugate to a rotation, see 2.4.2 below, as well as later in this paper in the proofs of Theorems 3.4, 4.1 and 5.1. However in certain cases, for example to achieve weak mixing, it is necessary to use more general constructions.

2.3. Closure of conjugacies. By controlling initial steps of the construction one can keep the final diffeomorphism f within any given C^∞ neighborhood of a given element S_α of the action \mathcal{S} . On the other hand, by applying a fixed diffeomorphism g first the construction can be carried out in a neighborhood of any diffeomorphism conjugate to an element of the action. Thus the closure \mathcal{A} of diffeomorphisms of the form gS_tg^{-1} in, say, C^∞ topology is a natural ambient space for considering what a construction of this type can produce. This was first noticed in [1, Section 7] in connection with ergodic properties with respect to the invariant volume and was used in [5] to control topological properties.

If the action \mathcal{S} has fixed points it is natural to consider a smaller space $\mathcal{A}_F \subset \mathcal{A}$, namely, the closure of gS_tg^{-1} where the conjugacy g fixes every point of the fixed point set F of the action \mathcal{S} . Obviously for $f \in \mathcal{A}_F$ every point of F is also fixed. There does not seem to be much difference between dynamical properties which may appear in the whole space \mathcal{A} and in \mathcal{A}_F . In Section 3.1 we will discuss the situation for the standard two-dimensional examples: the disc, the annulus and the sphere with S^1 action by rotations. At this point we would like to introduce also *restricted* spaces of conjugacy closures, namely for $\alpha \in \mathbb{R}/\mathbb{Z}$ we define the spaces \mathcal{A}_α and $\mathcal{A}_{F,\alpha}$ as the closure in C^∞ topology of the diffeomorphisms of the form $gS_\alpha g^{-1}$ where g is correspondingly an arbitrary C^∞ diffeomorphism, or a C^∞ diffeomorphism fixing every point of the set F . Since for any $\frac{p}{q} \in \mathbb{Q}$ and any $f \in \mathcal{A}_{\frac{p}{q}}$ one has $f^q = \text{Id}$, only spaces \mathcal{A}_α for irrational α 's are of interest.

Let us give a classical example showing that the space \mathcal{A} may be quite different from the union of \mathcal{A}_α

2.3.1. *The horocycle flow.* Consider the group $SL(2, \mathbb{R})$ and three one-parameter subgroups: the standard rotations $R_t = \begin{pmatrix} \cos 2\pi t & \sin 2\pi t \\ -\sin 2\pi t & \cos 2\pi t \end{pmatrix}$, the diagonals $G_t = \begin{pmatrix} e^t & 0 \\ 0 & e^{-t} \end{pmatrix}$ and the upper-triangular unipotents $H_t = \begin{pmatrix} 1 & t \\ 0 & 1 \end{pmatrix}$. The commutation relation

$$G_t R_s G_{-t} = \begin{pmatrix} \cos 2\pi s & e^{2t} \sin 2\pi s \\ -e^{-2t} \sin 2\pi s & \cos 2\pi s \end{pmatrix}$$

implies

$$\lim_{t \rightarrow \infty} G_t R_{\frac{e^{-2t}}{2\pi}} G_{-t} = H_1. \quad (2.5)$$

Now let Γ be a cocompact lattice in $SL(2, \mathbb{R})$. Since left translations on any group commute with right translations we can consider the actions of the one-parameter subgroups described above on the compact manifold $M = SL(2, \mathbb{R})/\Gamma$. In the case when Γ has no elliptic elements, M can be identified with the unit tangent bundle of a compact surface V of constant negative curvature, and the right actions of $\{G_t\}$ and $\{H_t\}$ are called the *geodesic flow* and *horocycle flow* on V correspondingly. [26, Sections 5.4 and 17.5]. We will denote the actions of R_t , G_t and H_t by right translations on $SL(2, \mathbb{R})/\Gamma$ by r_t , g_t and h_t correspondingly. The first of these is of course a S^1 action, while every nontrivial element of the last one is uniquely ergodic, mixing of all orders and has countable Lebesgue spectrum (see [29, Section 1.4e] and references thereof). It follows from 2.3.1 that

$$\lim_{t \rightarrow \infty} g_t r_{\frac{e^{-2t}}{2\pi}} g_{-t} = h_1.$$

Thus $h_1 \in \mathcal{A}$. But it is the limit of conjugacies of certain elements of the circle action which converge to zero.

PROPOSITION 2.1. $h_1 \notin \mathcal{A}_\alpha$ for any $\alpha \in S^1$.

Proof. Obviously $\mathcal{A}_0 = \{\text{Id}\}$; thus, we need to prove the statement for $\alpha \neq 0$; For any volume preserving diffeomorphism f of a compact manifold homotopic to identity one defines the *rotation class* $\rho(f)$ as an element of the first homology group of the direct product $M \times S^1$. It is constructed as the asymptotic cycle of the suspension flow of f [26, Section 14.7b]. The rotation class is continuous in C^0 topology and equivariant under the conjugacy. Thus $\rho(h_1) = 0$. On the other hand the projection of $\rho(r_\alpha)$ to the $H_1(M, \mathbb{R})$ has the form $\alpha\rho_0$, where ρ_0 is the nonzero integer homology class realized by the embedding of $SO(2)$ to $SL(2, \mathbb{R})/\Gamma$. Since the action of the diffeomorphism group by conjugacies respects the integer structure in this projection the rotation classes of elements of conjugates of r_α are separated from zero and hence for any $f \in \mathcal{A}_\alpha$, $\rho(f) \neq 0$. \square

The following question remains open:

PROBLEM 2.2. Does there exist a circle action S on a compact manifold and α such that the corresponding space \mathcal{A}_α contains a mixing transformation?

In Section 6 we will give a positive answer for a version of this question with a \mathbb{T}^3 action instead of an S^1 action. We will also provide more examples of circle actions with mixing transformations in the unrestricted space \mathcal{A} .

2.4. Generic and nongeneric constructions. The development of the approximation by conjugation method was motivated by several natural questions about ergodic properties of volume preserving diffeomorphisms. Here are two characteristic examples of such questions, both answered positively in [1]:

2.4.1. *Does there exist an ergodic area preserving diffeomorphism of the two-disc \mathbb{D}^2 ?*

2.4.2. *Does there exist a diffeomorphism of a compact manifold M , $\dim M > 1$ preserving a smooth volume and measurably conjugate to an irrational rotation of the circle?*

These positive answers looked somewhat surprising at the beginning: in the former case because usually near an elliptic fixed point there are many invariant curves making the map highly nonergodic; and in the latter because the eigenfunctions of any such transformation must be highly discontinuous. While there are ergodic diffeomorphisms of the disc without genuine elliptic points which exhibit much stronger stochastic properties than ergodicity [23], the original examples in [1] do have elliptic points and are in fact small perturbations of (nonergodic) rotations of the disc.

Constructions answering questions 2.4.1 and 2.4.2 are characteristic for two different versions of the approximation by conjugation method.

2.4.3. *Control at some time scales.* In the constructions of the first kind it is sufficient to control the behavior of approximating and hence resulting diffeomorphisms on a series of growing but unrelated time scales. The approximate pictures may look quite whimsical (see e.g. the original weak mixing construction in [1, Section 5] and a modern version in [14]), but as long as a diffeomorphism $f \in \mathcal{A}$ is close enough to conjugacies of rotations appearing in such pictures the property is guaranteed. In fact, for a proof of genericity in \mathcal{A} of a property exhibited by a construction of this sort no actual inductive construction is needed. One just needs to show that an approximate picture at each scale appears for an open dense subset of conjugacies of rotations. If appearance in an approximate picture at infinitely many growing scales guarantees the property then by the Baire category theorem the property holds for a dense G_δ subset on \mathcal{A} .

Ergodicity is generic in \mathcal{A} ; in the case of the disc with S^1 acting by rotations around the center this in particular implies that invariant circles which are very hard to avoid from the classical standpoint (twists, frequency locking, etc) can in fact be destroyed easily if one adopts a less conventional

point of view. We will discuss the disc diffeomorphisms in detail in Section 3.1 below.

Beyond ergodicity the basic ergodic properties which are generic in \mathcal{A} are arbitrary fast cyclic approximation (which implies ergodicity and also simple singular spectrum) [1, Theorem 7.1], and weak mixing. Those properties are among generic properties for measure preserving automorphisms of Lebesgue space in weak topology [27, 24] which also possess some more refined generic properties such as mutual singularity of the maximal spectral type and all its convolutions [24], or existence of roots of all orders [28]. The first of those as well as many others follows from the genericity of arbitrary fast periodic approximation of arbitrary type (not just cyclic) [24].

We will later discuss open questions and difficulties related with establishing genericity of such properties in \mathcal{A} (Section 7.2).

In this paper we present a new example of a generic construction in Section 3. A proper extension of this construction from the basic two-dimensional examples (the disc, the annulus and the sphere) to manifolds (with or without boundaries) with circle actions provides a common generalization of both genericity of ergodicity in the general case of nontrivial circle actions [1], and genericity of minimality and unique ergodicity in the case of fixed-point free actions on closed manifolds [5] (See Section 3.6).

2.4.4. *Control at all times.* In the constructions of the second kind including the one answering the question 2.4.2 approximations at different steps of the construction are linked and hence in principle *the asymptotic behavior of the resulting diffeomorphism is controlled for all times*. Such a construction is never generic in \mathcal{A} or any of the other spaces introduced in Section 2.3

Constructions of this kind appear most naturally when the resulting diffeomorphism is constructed to be measure-theoretically conjugate to a map of a particular kind such as a rotation in the question 2.4.2 or a translation on a torus of higher dimension [1, section 6]. Those constructions also appear in topological situations, for example in producing minimal diffeomorphisms with more than one ergodic measure [38]. Our construction in Section 4 is nongeneric although quite natural in the sense described at the end of Section 2.2, and is similar in some respects to the construction of a diffeomorphism conjugate to a rotation. One may also extend the construction from [38] to obtain extra invariant measures for the case of actions with fixed points or on manifolds with boundaries (such as four or more ergodic measures on the disc; see Section 3.7). The construction in Section 5 is also nongeneric and is of a similar type.

A new and quite different type of nongeneric constructions are those which produce mixing diffeomorphisms. Presently we need an action of \mathbb{T}^3 to carry out such a construction. This construction is based on the combination of approximation by conjugation and the methods developed by the first author for constructing mixing time changes for linear flows on \mathbb{T}^k , $k \geq 3$ [6, 7].

The latter may be interpreted as a “multiple frequencies” version of the approximation by conjugation method.

We would like to point out that Michel Herman was a great master in the use of Baire category theorem with results which were often striking (it was his “favorite theorem” according to Albert Fathi), and in particular he very effectively used generic constructions in the context of the method of approximation by conjugation. In his published work though he did not make any direct use of nongeneric constructions in the context of the approximation by conjugation method. It was however his original insight which stimulated the first author, his last Ph. D. student, to develop the nongeneric constructions of mixing diffeomorphisms.

3. DIFFEOMORPHISMS OF THE DISK, THE ANNULUS, AND THE SPHERE WITH EXACTLY THREE ERGODIC MEASURES.

3.1. Dynamics and invariant measures of disc diffeomorphisms.

The most basic fact about dynamics of diffeomorphisms of the disc \mathbb{D}^2 is presence of a fixed point (Brower fixed point theorem). Furthermore, for an area preserving map there is fixed point inside the disc.

As early as 1930 L.G. Shnirelman [37] in an attempt to prove a “converse” to the Brower theorem constructed an example of a topologically transitive homeomorphism h of \mathbb{D}^2 which in polar coordinates (ρ, θ) has the form

$$h(\rho, \theta) = (\rho + g(\theta), \theta + \alpha). \quad (3.1)$$

Shnirelman was mistaken in his assertion that every orbit inside the disc other than the origin was dense. For maps of the form (3.1) existence of nondense orbits in the interior can be easily shown. (A.S. Besicovitch who repeated this mistake later corrected it in [2]). It is also not too difficult to see that for any homeomorphism of the disc fixing the origin there are nondense *semiorbits* in the interior. Existence of nondense *orbits* is much more difficult and it was proven only recently (forty five years after the Besicovitch paper) by P. Le Calvez and J.-C. Yoccoz [4].

It is true however that the only ergodic invariant measures in the Shnirelman example are the δ -measure at the origin and Lebesgue measure on the boundary and that for almost every point with respect to the two-dimensional Lebesgue measure the asymptotic distribution exists and is exactly the average of these two measures. A careful study of the Shnirelman–Besicovitch examples was one of the sources which led Anosov and the second author to the invention of the approximation by conjugation method ([1, Introduction]).

Notice that unlike Shnirelman–Besicovitch maps any area preserving diffeomorphism of the disc has at least three ergodic invariant measures: the δ -measure at a fixed point inside the disc, a measure supported at the boundary plus any ergodic component of the area. Naturally, the only possibility to achieve this lower bound of three ergodic invariant measures

appears when there is only one fixed point inside, only one measure supported by the boundary and the map is ergodic with respect to the area (this is not sufficient though).

Now consider the closure spaces \mathcal{A} and \mathcal{A}_F of conjugacies of rotations described in Section 2.3. Every diffeomorphism $f \in \mathcal{A}_F$ preserves the origin, the boundary and the volume. In this section we will show that the minimal number of three ergodic invariant measures is achieved and is even generic in a properly defined sense. Moreover in our examples (albeit not generically) any point in the interior whose orbit closure is not dense (such points exist by [4]) has an asymptotic distribution which is either the δ measure at the origin, or Lebesgue measure on the boundary, in contrast with the Shnirelman–Besikovich maps of the form (3.1).

Any map $f \in \mathcal{A}$ preserves the boundary and hence has a rotation number on the boundary. By continuity for $f \in \mathcal{A}_\alpha$ this rotation number is equal to α . Our examples belong to spaces \mathcal{A}_α with α irrational but very well approximated by rationals (Liouvillean numbers). This is the only possibility for ergodicity with respect to the area in a space \mathcal{A}_α . For, if α is rational then every $f \in \mathcal{A}_\alpha$ is periodic. If α is Diophantine the restriction of every $f \in \mathcal{A}_\alpha$ to the boundary of \mathbb{D}^2 is C^∞ conjugate to the rotation R_α by the Herman–Yoccoz theorem [17, 39]. Hence as Herman proved in his unpublished work there are smooth f -invariant circles arbitrary close to the boundary and hence ergodicity or topological transitivity is not possible.

The only other way ergodicity may appear in the whole space \mathcal{A} would be for a map with a rational rotation number $\frac{p}{q}$ on the boundary which is a limit of conjugacies of rotations with variable rotation numbers converging to $\frac{p}{q}$. Passing to the q th powers one may assume without loss of generality that the rotation number on the boundary is zero. Such examples will in some sense be similar to maps from the horocycle flow, see 2.3.1. A special case of this situation which may be of importance for various constructions is to have a map which is the identity on the boundary. Let us summarize this discussion.

PROBLEM 3.1.

1. Does there exist an area preserving diffeomorphism of the disc preserving the origin, with zero rotation number on the boundary, and such that the area is the only invariant ergodic measure not supported at the origin or at the boundary?
2. Does there exist an area preserving diffeomorphism of the disc preserving the origin, which fixes every point of the boundary and such that the area is the only invariant ergodic measure not supported at the origin or at the boundary?

The following problem is related to both Problems 2.2 and 3.1

PROBLEM 3.2. Does there exist an area preserving mixing diffeomorphism of the disc D^2 with zero metric (or topological) entropy?

REMARK 3.3. Notice that such examples are known on any orientable surface of genus $g \geq 1$ with or without holes. They are obtained as time one maps of mixing flows first constructed by Kočergin [30]. They are not known on the sphere or the cylinder.

3.2. Statement and description of the construction. Notice that the pictures of rotations and conjugacies are essentially identical on the disc, the annulus $[0, 1] \times S^1$ and the sphere S^2 . In all three cases one has polar coordinates (ρ, θ) and the rotations are given by $S_t(\rho, \theta) = (\rho, \theta + t)$. Here $0 \leq \rho \leq 1$ and θ is the cyclic coordinate of period 1. All the conjugacies involved in our constructions will coincide with the identity near $r = 0$ and $r = 1$, hence the difference between the three cases will be insignificant. Accordingly our drawings will refer to the case of the annulus which is easier to represent graphically. Let us call the Lebesgue measure on the manifold, the δ -measures at the fixed points of the rotations and Lebesgue measures on the boundary components the *natural measures*.

THEOREM 3.4. *Let M be \mathbb{D}^2 , $[0, 1] \times S^1$ or S^2 , and S_t be the standard action by rotations. There exists a C^∞ diffeomorphism $f : M \rightarrow M$ that has exactly three ergodic invariant measures: the natural measures on M . Furthermore, diffeomorphisms with this property form a residual set in the space \mathcal{A}' : the closure in the C^∞ topology of the conjugates of rotations with conjugacies fixing the fixed points of S and every point of the boundary.*

We will call the boundary components and fixed points of the rotations *singularities*. At step $n - 1$, h_{n-1} is constructed and then α_n is chosen. We assume that after step $n - 1$ there are two neighborhoods of the singularities B_{n-1}^l and B_{n-1}^r on which $H_{n-1} \equiv \text{Id}$. At step n we define three collections of closed sets $\delta_n^l = \{\delta_{n,i}^l, i = 1, \dots, l_n\}$, $\delta_{n,i}^l \subset B_{n-1}^l$, $\delta_n^r = \{\delta_{n,i}^r, i = 1, \dots, l_n\}$, $\delta_{n,i}^r \subset B_{n-1}^r$ and $\xi_n = \{\xi_{n,i}, i = 1, \dots, l_n\}$, the collection of kernels. These collections will have the property that the union of their atoms capture an increasingly large proportion of *any* rotation orbit. The map h_n is then chosen so that the images of the kernels $H_n(\xi_{n,i})$ have small diameters, and such that $H_n \equiv \text{Id}$ on two smaller neighborhoods of the singularities B_n^l and B_n^r that still contain all elements of δ_n^l and δ_n^r correspondingly. At the end of step n , α_{n+1} is chosen to insure convergence of the construction. We will use polar coordinates (ρ, θ) in our calculations.

3.3. Properties of the collections ξ_n , δ_n^r and δ_n^l . $0 \frac{\text{Define}}{\|H_{n-1}\|_{C^1}^3} (3.1)$

considered $B_{n-1}^l \subset [1, 1 - 1/(n-1)] \times \mathbf{T}$. The following proposition gives a description of the configuration describing precision of the configuration can be made arbitrarily small since we are free to take l_n arbitrarily large.

PROPOSITION 3.5. *Assuming that neighborhoods B_{n-1}^l and B_{n-1}^r of the boundary components are given and given any $\eta_n > 0$, there exists an integer l_n multiple of q_n and three collections of disjoint closed sets on M , δ_n^l , δ_n^r and ξ_n each one containing l_n elements and satisfying*

1. δ_n^l , δ_n^r and ξ_n are invariant by $S_{\frac{1}{l_n}}$ and $\xi_{n,1} \subset (0, 1) \times (0, \frac{1}{l_n})$, $\delta_{n,1}^l \subset [0, 1/n] \times (0, \frac{1}{l_n})$ and $\delta_{n,1}^r \subset [1 - 1/n, 1] \times (0, \frac{1}{l_n})$,
2. $\mu(\xi_{n,1}) \leq \eta_n$ and $\mu(\bigcup \xi_{n,i}) \geq 1 - \eta_n$.
3. $\delta_{n,i}^l \subset B_{n-1}^l$ and $\delta_{n,i}^r \subset B_{n-1}^r$
4. Any circle $V_\rho = \{\rho\} \times S^1$ intersects the three collections in the following way: there exists a constant $c_n(\rho) \in [0, 1]$ with $c_n(1/2) = 1$, $c_n(0) = c_n(1) = 0$ and such that for any $1 \leq i \leq l_n$, $V_\rho \cap \xi_{n,i}$ is an empty set, a point or a segment and so are $V_\rho \cap \delta_{n,i}^l$ and $V_\rho \cap \delta_{n,i}^r$; moreover we require that

$$(1 - \eta_n) \frac{c_n(\rho)}{l_n} \leq |V_\rho \cap \xi_{n,i}| \leq (1 + \eta_n) \frac{c_n(\rho)}{l_n},$$

and if $\rho \in [0, 1/2]$, $V_\rho \cap \delta_n^r = \emptyset$ while

$$(1 - \eta_n) \frac{(1 - c_n(\rho))}{l_n} \leq |V_\rho \cap \delta_{n,i}^l| \leq (1 + \eta_n) \frac{(1 - c_n(\rho))}{l_n},$$

and if $\rho \in [1/2, 1]$, $V_\rho \cap \delta_n^l = \emptyset$ while

$$(1 - \eta_n) \frac{(1 - c_n(\rho))}{l_n} \leq |V_\rho \cap \delta_{n,i}^r| \leq (1 + \eta_n) \frac{(1 - c_n(\rho))}{l_n}.$$

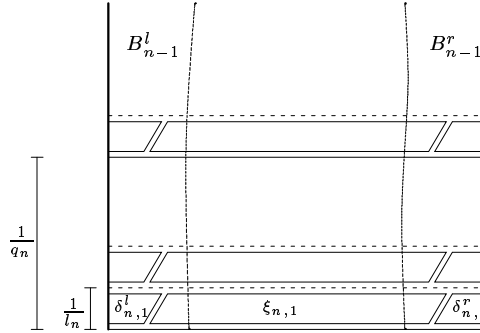

Fig. 3.1. The collections ξ_n , δ_n^l , and δ_n^r .

3.4. Properties of the successive conjugating diffeomorphisms H_n .

Using the collections of sets introduced in §3.3, we will state and prove some sufficient conditions on the sequences α_n and H_n that guarantee the convergence in (2.1) to a diffeomorphism having exactly three invariant ergodic measures as in Theorem 3.2. We require that the collections in Proposition 3.5 be constructed with $\eta_n \rightarrow 0$ and we will extract later more information on how fast η_n should converge to 0.

LEMMA 3.6. *If $\alpha_n = \frac{p_n}{q_n}$ is a sequence of rationals and H_n is a sequence of diffeomorphisms of M satisfying (2.2) and (2.3), and if there exists a sequence $\epsilon_n \rightarrow 0$ such that for every n large enough we have*

1. $H_n \equiv \text{Id}$ on two open neighborhoods B_n^l of $\{0\} \times S^1$ and B_n^r of $\{1\} \times S^1 \times \mathbf{T}$ and satisfying

$$\delta_{n,i}^j \subset B_n^j \subset B_{n-1}^j, \quad j = r, l, \quad i = 1, \dots, l_n.$$

2. For any $i = 1, \dots, l_n$,

$$\text{diam}(H_n(\xi_{n,i})) \leq \epsilon_n,$$

3. $|\alpha_{n+1} - \alpha_n| < \max(\frac{1}{2^n \|H_n\|_{C^n}}, \frac{1}{2^n q_n \|H_n\|_{C^1}})$, and $q_{n+1} \geq nl_n$,

then $H_n \circ S_{\alpha_{n+1}} \circ H_n^{-1}$ converges in the C^∞ topology to a diffeomorphism f having exactly three invariant ergodic measures: the Lebesgue measure μ on M and the measures δ^l and δ^r supported on the singularities corresponding to Lebesgue measures on $\{0\} \times S^1$ and $\{1\} \times S^1$ respectively.

REMARK 3.7. In §3.5 we will have to construct h_n so that H_n fulfills conditions (1) and (2) above. Condition (1) is consistent with (3) in Proposition 3.5 and condition (2) above will be consistent with (2) in Proposition 3.5 if at step n we choose $\eta_n \leq (\epsilon_n / \|H_{n-1}\|_{C^1})^3$.

3.4.1. *Convergence.* Condition (3) of Lemma 3.6 insures convergence of $f_n = H_n \circ S_{\alpha_{n+1}} \circ H_n^{-1}$ to a volume preserving diffeomorphism f and the choice of α_{n+1} is made only after h_n is constructed. It also insures the closeness between f^m and f_n^m as $m \leq q_{n+1}$ (Cf. §3.4.3). The last condition, $q_{n+1} \geq nl_n$, guarantees that for any point in M a $(1 - \frac{1}{\eta_n})$ -proportion of its q_{n+1} (vertical) orbit under $S_{\alpha_{n+1}}$ is captured by the atoms of ξ_n , δ_n^l and δ_n^r which is crucial in the estimations of ergodic averages (Cf. (3.12) and (3.13)).

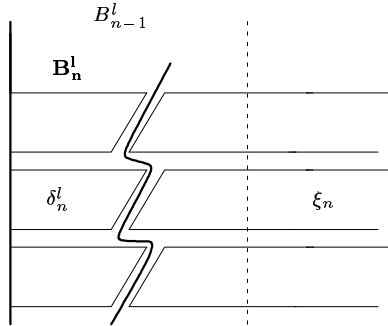

Fig. 3.2. $B_n^l \subset B_{n-1}^l$.

PROOF OF LEMMA 3.6. For $\varphi \in C^\infty(M, \mathbb{C})$ we use the notations

$$\begin{aligned}\hat{\varphi} &= \int_M \varphi(u, v) du dv, \\ \hat{\varphi}^l &= \int_{S^1} \varphi(0, v) dv, \\ \hat{\varphi}^r &= \int_{S^1} \varphi(1, v) dv.\end{aligned}$$

3.4.2. *Criterion for the existence of exactly three ergodic invariant measures.* Fix $\varphi \in C^\infty(M, \mathbb{C})$ and $z \in M$ and denote by $S_{f,m}\varphi(z)$ the Birkhoff sums

$$S_{f,m}\varphi(z) = \varphi(z) + \varphi(f(z)) + \dots + \varphi(f^{m-1}(z)).$$

Lemma 3.6 clearly follows if we prove that there exists a sequence of functions $\varepsilon_n \rightarrow 0$, a sequence $m_n \rightarrow \infty$ and a sequence $c_n(z) \in [0, 1]$ such that for either $j = l$ or $j = r$ we have

$$c_n(z)\hat{\varphi} + (1 - c_n(z))\hat{\varphi}^j - \varepsilon_n \leq \frac{S_{f,m_n}\varphi(z)}{m_n} \leq c_n(z)\hat{\varphi} + (1 - c_n(z))\hat{\varphi}^j + \varepsilon_n \quad (3.2)$$

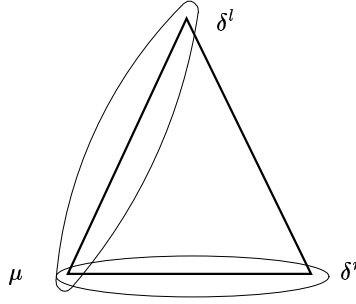

Fig. 3.3. The simplex of invariant measures and possible averages for a large m_n .

3.4.3. *The diffeomorphisms f and $f_n = H_n \circ S_{\alpha_{n+1}} H_n^{-1}$.* It follows from condition (3) of Lemma 3.6 that

LEMMA 3.8. *For any $m \leq q_{n+1}$ we have*

$$\|f^m - f_n^m\|_{C^1} \leq \frac{1}{2^n}.$$

PROOF. Since h_{n+1} commutes with $S_{\alpha_{n+1}}$ we have that $f_n = H_{n+1} \circ S_{\alpha_{n+1}} H_{n+1}^{-1}$ hence

$$\begin{aligned}\|f_{n+1}^m - f_n^m\|_{C^1} &\leq \|H_{n+1}\|_{C^1} m |\alpha_{n+2} - \alpha_{n+1}| \\ &\leq m \frac{1}{2^{n+1} q_{n+1}}\end{aligned}$$

which yields the conclusion of the lemma. \square

As a consequence (3.2) will follow (with some $\varepsilon'_n \rightarrow 0$) if we pick $m_n = q_{n+1}$ and prove that for a sequence $\varepsilon_n \rightarrow 0$ we have

$$c_n \hat{\varphi} + (1 - c_n) \hat{\varphi}^j - \varepsilon_n \leq \frac{S_{f_n, q_{n+1}} \varphi(z)}{q_{n+1}} \leq c_n \hat{\varphi} + (1 - c_n) \hat{\varphi}^j + \varepsilon_n. \quad (3.3)$$

3.4.4. *Control of a large proportion of any orbit.* The point $z \in M$ being fixed we write it as $H_n(\rho_0, \theta_0)$ so that

$$f_n^m(z) = H_n \circ S_{\alpha_{n+1}}^m(\rho_0, \theta_0).$$

For a set $A \subset M$ we define

$$L_{q_{n+1}}(A) := \{0 \leq m \leq q_{n+1} - 1 \mid S_{\alpha_{n+1}}^m(\rho_0, \theta_0) \in A\}.$$

The following lemma is a straightforward consequence of (4) of Proposition 3.5

LEMMA 3.9. *We have for every $1 \leq i \leq l_n$,*

$$(1 - \eta_n) \frac{q_{n+1} c_n(\rho_0)}{l_n} - 1 \leq \#L_{q_{n+1}}(\xi_{n,i}) \leq (1 + \eta_n) \frac{q_{n+1} c_n(\rho_0)}{l_n} + 1, \quad (3.4)$$

and

$$\begin{aligned} (1 - \eta_n) \frac{q_{n+1}(1 - c_n(\rho_0))}{l_n} - 1 &\leq \#L_{q_{n+1}}(\delta_{n,i}^j) \\ &\leq (1 + \eta_n) \frac{q_{n+1}(1 - c_n(\rho_0))}{l_n} + 1, \end{aligned} \quad (3.5)$$

where $j = l$ if $\rho_0 \leq 1/2$ and $j = r$ if $\rho_0 \geq 1/2$.

In particular, the number of points among the first q_{n+1} iterates of (ρ_0, θ_0) under $S_{\alpha_{n+1}}$ that are not considered in the lemma is less than $2\eta_n q_{n+1} + 4l_n$.

3.4.5. *Estimating φ on $H_n(\xi_n)$.* Proposition 3.5 and the fact that S_i and H_n preserve the area μ imply that $1 - \eta_n \leq l_n \mu(H_n(\xi_{n,i})) < 1$ for any $i \leq l_n$. Hence, as a consequence of condition (2) in Lemma 3.6 there exists a sequence $\varepsilon_{1,n} \rightarrow 0$ such that for any $(\rho, \theta) \in H_n(\xi_{n,i})$ we have

$$\begin{aligned} (1 - \varepsilon_{1,n}) \int_{H_n(\xi_{n,i})} \varphi(u, v) dudv &\leq \frac{1}{l_n} \varphi(\rho, \theta) \\ &\leq (1 + \varepsilon_{1,n}) \int_{H_n(\xi_{n,i})} \varphi(u, v) dudv. \end{aligned} \quad (3.6)$$

On the other hand property (2) in Proposition 3.5 and the fact that H_n preserves μ also implies that there exists $\varepsilon_{2,n} \rightarrow 0$ such that

$$(1 - \varepsilon_{2,n}) \hat{\varphi} \leq \sum_{i=1}^{l_n} \int_{H_n(\xi_{n,i})} \varphi(u, v) dudv \leq (1 + \varepsilon_{2,n}) \hat{\varphi}, \quad (3.7)$$

where we recall that $\hat{\varphi} = \int_M \varphi(u, v) dudv$.

3.4.6. *Estimating φ on $H_n(\delta_n^l)$ and $H_n(\delta_n^r)$.* As a consequence of (1) in Proposition 3.5, there exists a sequence $\epsilon_{3,n}$ such that for any $(\rho, \theta) \in \delta_{n,i}^l$, we have that

$$(1 - \epsilon_{3,n})\varphi(0, \frac{i}{l_n}) \leq \varphi(\rho, \theta) \leq (1 + \epsilon_{3,n})\varphi(0, \frac{i}{l_n}). \quad (3.8)$$

On the other hand there exists a sequence $\epsilon_{4,n} \rightarrow 0$ such that

$$(1 - \epsilon_{4,n})\hat{\varphi}^l \leq \frac{1}{l_n} \sum_{i=1}^{l_n} \varphi(0, \frac{i}{l_n}) \leq (1 + \epsilon_{4,n})\hat{\varphi}^l, \quad (3.9)$$

where as before $\hat{\varphi}^l = \int_{S^1} \varphi(0, v) dv$. Similar equations as (3.8) and (3.9) hold for $(\rho, \theta) \in \delta_{n,i}^r$ and $\hat{\varphi}^r = \int_{S^1} \varphi(1, v) dv$.

3.4.7. *Proof of (3.3).* We will assume for definiteness that $z = H_n(\rho_0, \theta_0)$ with $\rho_0 \leq 1/2$ the case $\rho_0 \geq 1/2$ being similar. q_{n+1} points of the first q_{n+1} iterates by $S_{\alpha_{n+1}}$ of (ρ_0, θ_0) . In light of Lemma 3.9 and (3.6)–(3.9) we get the following estimations of

$$U_n := \frac{1}{q_{n+1}} S_{f_n, q_{n+1}} \varphi(\rho_0, \theta_0)$$

$$V_n^1 + V_n^2 + V_n^3 \leq U_n \leq U_n^1 + U_n^2 + U_n^3 \quad (3.10)$$

where U_n^3 is a bound on the contribution of the non-controlled points

$$U_n^3 \leq 2(\epsilon_n + \frac{2l_n}{q_{n+1}}) \|\varphi\|, \quad (3.11)$$

and U_n^1 is relative to the points that fall in $H_n(\xi_n)$ for which we use (3.4) of Lemma 3.9 and (3.6) and (3.7) to obtain the following upper bound on their contribution

$$\begin{aligned} U_n^1 &= \frac{1}{q_{n+1}} \sum_{i=1}^{l_n} \left[(1 + \eta_n) \frac{c_n(\rho_0) q_{n+1}}{l_n} + 1 \right] (1 + \epsilon_{1,n}) \int_{H_n(\xi_{n,i})} \varphi(u, v) du dv \\ &\leq (1 + \eta_n)(1 + \epsilon_{1,n})(1 + \epsilon_{2,n}) c_n(\rho_0) \hat{\varphi} + \frac{l_n}{q_{n+1}} \|\varphi\|, \end{aligned} \quad (3.12)$$

and U_n^2 is a bound on the contribution of the points in δ_n^l for which (3.5) of Lemma 3.9 and (3.8) and (3.9) lead to

$$\begin{aligned} U_n^2 &= \frac{1}{q_{n+1}} \sum_{i=1}^{l_n} \left[(1 + \eta_n) \frac{(1 - c_n(\rho_0)) q_{n+1}}{l_n} + 1 \right] (1 + \epsilon_{3,n}) \varphi(0, \frac{i}{l_n}) \\ &\leq (1 + \eta_n)(1 + \epsilon_{3,n})(1 + \epsilon_{4,n})(1 - c_n(\rho_0)) \hat{\varphi}^l + \frac{l_n}{q_{n+1}} \|\varphi\|. \end{aligned} \quad (3.13)$$

Recall that α_{n+1} is chosen such that $l_n/q_{n+1} \leq 1/n$, hence (3.11)–(3.13) with similar lower bounds for V_n^1 , V_n^2 and V_n^3 yield (3.3). This finishes the proof of Lemma 3.6. \square

3.5. Construction of h_n and choice of α_{n+1} . In this section we construct h_n and choose α_{n+1} so that the conditions of Lemma 3.6 hold for $H_n = h_1 \circ \dots \circ h_n$.

We fix a sequence $\epsilon_n \rightarrow 0$. We assume that the conditions of Lemma 3.6 hold up to step $n - 1$ and consider a configuration of collections as in Proposition 3.5 with

$$\eta_n = (\epsilon_n / \|H_{n-1}\|_{C^1})^3. \quad (3.14)$$

Then we have

PROPOSITION 3.10. *There exists a diffeomorphism h_n of class C^∞ on M and two neighborhoods B_n^l and B_n^r of the singularities with $\delta_n^j \subset B_n^j \subset B_{n-1}^j$, $j = l, r$, such that*

1. h_n is volume preserving,
2. $h_n \circ S_{\alpha_n} = S_{\alpha_n} \circ h_n$,
3. $h_n \equiv \text{Id}$ on $B_n^l \cup B_n^r$
4. For every $\xi_{n,i} \in \xi_n$, $\text{diam}(h_n(\xi_{n,i})) \leq \frac{\epsilon_n}{\|H_{n-1}\|_{C^1}}$.

Proof. As explained in Remark 3.7, (3) above is possible due to (3) in Proposition 3.5 and the fact that the unions of the sets in the collections δ_n^j , $j = l, r$ are closed while B_{n-1}^j , $j = l, r$ are open. Condition (2) can be realized in particular with $h_n \equiv \text{Id}$ on the singularities of the fundamental domain $[0, 1] \times [0, 1/q_n]$ due to (1) in Proposition 3.5 and to the fact that l_n is a multiple of q_n . Condition (4) can be realized since $\mu(\xi_{n,i}) \leq \eta_n$ and that we chose in (3.14) $\eta_n = (\epsilon_n / \|H_{n-1}\|_{C^1})^3 = o((\epsilon_n / \|H_{n-1}\|_{C^1})^2)$. \square

Checking the conditions of Lemma 3.6. Clearly, Conditions (1) and (2) on H_n in Lemma 3.6 follow respectively from (3) and (4) of Proposition 3.10. Finally the choice of α_{n+1} is done so that condition (3) of Lemma 3.6 holds. The construction is thus completed. \square

Proof of genericity of diffeomorphisms with three ergodic measures in \mathcal{A}' . Fix a function φ and $\epsilon > 0$, and define for an integer m and a function c the set $S(\varphi, \epsilon, m, c)$ of maps $f \in \mathcal{A}'$ such that the averages at time m are close to $c\mu + (1 - c)\delta$. This set is open by definition. We actually proved that the union over c and over m is dense hence the intersection over a countable base φ_i and a sequence $\epsilon_j \rightarrow 0$ is a dense G_δ . \square

3.6. Minimal number of invariant measures in the closure of conjugacies. Consider a general setting for approximation by conjugation construction, namely a smooth action S of the circle on a compact manifold M , possibly with boundary. For the special case of fixed point free actions on closed manifolds Fathi and Herman showed [5] that there is a residual subset of \mathcal{A} which consists of uniquely ergodic diffeomorphisms.

A proper fairly straightforward generalization of the construction described above produces in the case of a general S^1 action on a closed manifold

a residual subset of \mathcal{A}_F which consists of diffeomorphisms with only one invariant measure (the smooth volume) not supported on the set F . In other words, ergodic invariant measures for such a diffeomorphism are δ measures at the points of F and the smooth volume.

The only essential extra observation concerns the structure of orbits of a circle action near the set F . In order to obtain a proper counterpart of the picture presented on Figure 3.2 one needs to take an \mathbb{S} invariant neighborhood of a connected component of F in place of a thin vertical strip and perturb it in a $S_{\frac{1}{q}}$ invariant way to make it mostly transversal to the orbits.

The general case of a manifold with boundary in dimension greater than 2 is slightly more complicated. Unlike the disc and the annulus where the action \mathbb{S} on the boundary components is transitive and hence has ergodic elements, in this case in order to minimize the number of ergodic measures, one needs to carry out the construction to the boundary. This can be done with a certain care, the result being a diffeomorphism in \mathcal{A}_F whose only nonatomic ergodic measures are the smooth volume and smooth measures on connected components of the boundary. A good test case to understand this picture is the three-dimensional closed ball \mathbb{D}^3 with the circle action by rotations around a fixed axis. A perturbation we are referring to is ergodic volume preserving, ergodic area preserving on the boundary, fixes every point of the rotation axis, and has no other ergodic invariant measures.

3.7. More measures. It is natural to ask how the number of ergodic invariant measures can be increased in a controlled way. We will briefly discuss the standard cases of area preserving diffeomorphisms of the annulus, the disc, and the sphere. Higher dimensional cases are actually easier to handle.

An obvious way to produce an example with any odd number $2m+1$, $m \geq 2$ of invariant measures is by pasting m annuli, or $m-1$ annuli capped on one side by a disc, or $m-2$ annuli capped on each side by a disc, with diffeomorphisms described earlier in this section. One picks the same rotation number in each copy and since our examples are C^∞ tangent to the corresponding rotation on the boundary the resulting diffeomorphisms will be C^∞ . Naturally these examples are neither ergodic nor topologically transitive.

A modification of our method allows to produce in the spaces \mathcal{A}' topologically transitive diffeomorphisms with exactly $m \geq 4$ ergodic invariant measures all but two of which are absolutely continuous. These diffeomorphisms are naturally not ergodic with respect to the area measure. Construction remains the same near the singularities while inside instead of a single parallelogram $\xi_{n,1}$ and its shifts one takes $m-2$ next to each other in such a way that their union still intersects every vertical line by a set of large conditional measure to guarantee a counterpart of condition (4) of Proposition 3.5. The images of those parallelograms have small diameters (Cf. Lemma 3.6, (3)). At this step however there is a new element in the

construction which makes it nongeneric. There are $m - 2$ invariant cylinders whose images will represent distributions which we intent to have as approximating ergodic absolutely continuous invariant measures for the limit diffeomorphism. These distributions must converge at least weakly. We may in fact make their densities converge in L_1 by keeping most of each cylinder inside itself. However extra steps are needed to provide topological transitivity. This is done by sending a small number of parallelograms in each of $m - 2$ collection to other cylinders. A construction of this kind in a more general and considerably more complicated setting is described in detail in [38].

Finally, it is possible to increase the number of ergodic invariant measures in a controlled way keeping the volume ergodic; furthermore, the additional singular ergodic measure may be made supported by the whole manifold. To demonstrate how this works in the leading special case we as before will briefly describe a construction on any of the three standard two-dimensional manifolds (the disc, the annulus and the sphere) of an area preserving ergodic C^∞ diffeomorphism with a given number any $n \geq 4$ of ergodic invariant measures of which $n - 3$ are singular measures supported on the whole manifold. Since this construction combines ideas from the constructions of Theorems 3.4 and 4.1, it will be natural to describe it in the next section after the proof of the latter theorem.

4. MINIMAL SETS WITH ARBITRARY MEASURE.

4.1. Preliminaries. In this section we describe an answer to a question posed in 1977 in the paper by Fathi and Herman [5, Problem 1.6]. We do not claim any particular novelty or originality; rather our goal is to put the question into the general context of the approximation by conjugation method and indicate a variety of possible topological and ergodic properties for exotic minimal sets. A similar construction for the disc case can be found in Handel's paper [15]. Handel shows that his minimal set is nowhere locally connected (in fact a pseudo-circle) although he does not address the question about its Lebesgue measure. Herman himself produced similar examples for rational maps of the Riemann sphere [19].

THEOREM 4.1. *Let M be an m -dimensional differentiable manifold $m \geq 2$, μ a normalized smooth volume on M . Given any number $s \in [0, 1)$ there exists a compactly supported C^∞ diffeomorphism f of M preserving μ and a compact invariant minimal set C of f such that*

1. $\mu(C) = s$
2. *the set C is connected, has dimension $m - 1$ and is not homeomorphic locally to a product of \mathbb{R}^{m-1} with a Cantor set.*

Furthermore, f can be chosen arbitrary close to identity in the C^∞ topology.

As in the previous section we use an appropriately adjusted version of the approximation by conjugation method of Section 2.1. By specifying the parameters of the construction extra information can be provided both

about topology of the set C and about topological and measure–theoretic (ergodic) properties of f restricted to that set. We will discuss this after the proof of the theorem in its basic form.

REMARK 4.2. If the manifold M admits a nontrivial smooth action of the circle a proper modification of our construction allows to construct a diffeomorphism with a minimal set with desired properties in any C^∞ neighborhood of any element of the circle action.

4.2. Reduction to $\mathbb{D}^{m-1} \times S^1$. Consider the product $P = \mathbb{B}^{m-1} \times S^1$ of the $m - 1$ -dimensional open unit ball with the circle. Let λ be the product of normalized Lebesgue measures. We will call the $m - 1$ -dimensional direction “horizontal” and draw it accordingly, and the S^1 direction “vertical”. The action of the circle on P by vertical translations will be denoted $\mathcal{S} = \{S_t\}$ as usual. In the natural system of coordinates (ρ, θ) one obviously has $S^t(\rho, \theta) = (\rho, \theta + t)$.

Topology of M is essentially eliminated from our subsequent considerations due to the following fact.

PROPOSITION 4.3. *Given any $\epsilon > 0$ there exists a C^∞ diffeomorphic embedding $E : P \rightarrow M$ such that $\mu(E(P)) > 1 - \epsilon$ and $E_*(\lambda)$ is a scalar multiple of μ .*

Proof. Let $E_0 : P \rightarrow M$ be an arbitrary C^∞ diffeomorphic embedding. Then $(E_0)_*(\lambda) = \rho\mu$, where ρ is a positive C^∞ function defined on the manifold with boundary $E_0(P) \subset M$ and by definition $\int_{E_0(P)} \rho d\mu = 1$. Extend ρ to a positive C^∞ function on the whole manifold M which we will still denote by ρ in such a way that $\int_M \rho d\mu > (1 - \epsilon)^{-1}$. By the Moser Theorem [32] there exists a diffeomorphism $h : M \rightarrow M$ such that $h_*(\rho\mu) = (\int_M \rho d\mu)\mu$. Now take $E = h \circ E_0$. \square

Thus, it is enough to prove the theorem for the particular case of the open manifold P with the measure λ . A compactly supported diffeomorphism of P is translated to $E(P) \subset M$ via the embedding E and is extended by identity to the rest of M .

In fact we will deal with the product $\mathbb{D}^{m-1} \times S^1$ of the closed ball with the circle and will construct a diffeomorphism with the desired minimal set which on the boundary $S^{m-2} \times S^1$ coincides with a certain element S_α of the action \mathcal{S} . By slightly shrinking the horizontal direction by a homothety and extending the diffeomorphism to P by vertical rotations with the angle depending smoothly on the radius and decreasing from α to identical zero near the boundary we produce the desired compactly supported diffeomorphism of P .

4.3. Statement and description of the construction.

PROPOSITION 4.4. *Given any $s \in [0, 1)$, there exists a sequence α_n of rationals and a sequence H_n of diffeomorphisms preserving λ and constructed as in (2.2) and (2.3), such that the sequence of diffeomorphisms $H_n S_{\alpha_{n+1}} H_n^{-1}$*

converges in the C^∞ topology to a diffeomorphism of $\mathbb{D}^{m-1} \times S^1$ preserving λ and a compact invariant minimal set of measure s .

Moreover, f can be made arbitrary close to identity in the C^∞ topology.

4.3.1. Criterion of minimality.

DEFINITION 4.5. Let f be a map on a complete separable metric space M . Given $\epsilon > 0$ and a subset $A \subset M$, we say that f is ϵ -minimal on A if given any two points $x, y \in A$, there exists $n = n(x, y) \in \mathbf{N}$ such that $d(f^n(x), y) < \epsilon$.

If m is such that n as above can be chosen less than m for any pair $x, y \in A$ we say that f is (ϵ, m) -minimal on A .

LEMMA 4.6. If $A_n \subset M$ is a sequence of closed sets such that

1. For every $n \in \mathbf{N}$, $f(A_n) = A_n$,
2. There exists a sequence $\epsilon_n \rightarrow 0$ such that f is ϵ_n -minimal on A_n ,

then $\bigcap_{n \in \mathbf{N}} A_n$ is a minimal set for f .

Proof. We have that $A = \bigcap A_n$ is a closed set and that $f(A) \subset A$. On the other hand, given any two points $x, y \in A$, there exists a sequence k_n such that $d(f^{k_n}(x), y) < \epsilon_n$, hence A is a minimal set for f . \square

REMARK 4.7. In our construction, we will have A_n decreasing and $\mu(A_n) \rightarrow s$, where s is arbitrarily chosen in $(0, 1)$.

4.3.2. *Properties of the successive conjugating diffeomorphisms H_n .* In addition to the condition (2.4) that yields convergence in (2.1) we will now list certain extra conditions on the sequences α_n and H_n under which the limiting map will possess a minimal invariant set of the given measure $s \in [0, 1)$. In the next subsection we will show how at step n h_n is constructed such that the required conditions on H_n hold, then choose α_{n+1} to satisfy the remaining requirements.

Denote by $B(r)$ the ball in \mathbb{R}^{m-1} of radius r around the origin and let r_s be such that $\lambda(B(r_s)) = s$. For n large enough we consider in M the set $C_n = B(r_s + \frac{1}{n}) \times S^1$.

LEMMA 4.8. If α_n is a sequence of rationals and H_n is a sequence of diffeomorphisms of M satisfying (2.2) and (2.3), and if for some sequence $\epsilon_n \rightarrow 0$, one can find a sequence m_n such that

1. $H_n \equiv H_{n-1}$ outside the interior of C_{n-1} ,
2. $H_n S_{\alpha_{n+1}} H_n^{-1}$ is (ϵ_n, m_n) -minimal on $H_n(C_n)$,
3. $|\alpha_{n+1} - \alpha_n| < \max(\frac{1}{2^n \|H_n\|_{C_n}}, \frac{1}{2^n m_{n-1} \|H_n\|_{C_1}})$,

then the sequence $H_n S_{\alpha_{n+1}} H_n^{-1}$ converges in the C^∞ topology to a diffeomorphism f that preserves λ and is minimal on the set $\bigcap H_n(C_n)$ whose measure is equal to s .

Proof. Condition (3) implies convergence to a volume preserving C^∞ diffeomorphism f (Cf. (2.4) in §2.1). We claim that (1) implies that $f(H_n(C_n)) =$

$H_n(C_n)$: Indeed since H_{n+1} and H_n coincide on the boundaries of C_n we have that $H_{n+1}(C_n) = H_n(C_n)$ and by induction $H_l(C_n) = H_n(C_n)$ for any $l \geq n$. Hence $H_l S_{\alpha_{l+1}} H_l^{-1} H_n(C_n) = H_l S_{\alpha_{l+1}} C_n = H_l C_n = H_n(C_n)$ and the claim follows as $l \rightarrow \infty$. The sets $H_n(C_n)$ are nested, and $\lambda(H_n(C_n)) = \lambda(C_n) \rightarrow s$, hence $\lambda(\bigcap H_n(C_n)) = s$.

Condition (3) implies as in Lemma 3.8 of §3 that $\|f^m - H_n \circ S_{\alpha_{n+1}}^m \circ H_n^{-1}\| \leq \frac{m}{2^n m_n}$, hence (2) implies that f itself is $(\epsilon_n + 1/2^n, m_n)$ -minimal on $H_n(C_n)$. The fact that the set $\bigcap H_n(C_n)$ is a minimal set for f then follows from Lemma 4.6. \square

In the next lemma we will show how to deduce conditions (2) and (3) of the previous lemma from certain conditions on H_n and α_n that, unlike (2), do not involve explicit iterations.

DEFINITION 4.9. We will say that a collection ξ of subsets of the set $C = B(r) \times S^1$ is an (ϵ, ν) -collection of horizontal strips if

1. The elements ξ_i of ξ are disjoint and have the form $\xi_i = B(r) \times J_i$, where J_i is a segment of S^1 of length $|J_i| \geq \nu$.
2. $\lambda(\bigcup_i \xi_i) \geq \lambda(C) - \epsilon$.

REMARK 4.10. Let $\alpha_{n+1} = p_{n+1}/q_{n+1}$ with p_{n+1} and q_{n+1} relatively prime. Then given any $(\rho, \theta) \in C_n$ and any horizontal strip ξ in C_n of width larger than $1/q_{n+1}$ there exists $m \leq q_{n+1}$ such that

$$S_{\alpha_{n+1}}^m(\rho, \theta) = (\rho, \theta + m\alpha_{n+1} \bmod(1)) \in \xi$$

The following lemma implies Lemma 4.8 with $m_n = q_{n+1}$.

LEMMA 4.11. *If $\alpha_n = p_n/q_n$ is a sequence of rationals and H_n is a sequence of diffeomorphisms of M satisfying (2.2) and (2.3), and if we have for some sequence $\epsilon_n \rightarrow 0$ a sequence $\xi_n = \{\xi_{n,i}\}$ of $(\frac{1}{n}, \frac{1}{q_{n+1}})$ -collections of horizontal strips in C_n such that*

1. $H_n \equiv H_{n-1}$ outside the interior of C_{n-1} ,
2. For any element $\xi_{n,i} \in \xi$, $\text{diam}(H_n(\xi_{n,i})) \leq \epsilon_n$,
3. $|\alpha_{n+1} - \alpha_n| < \max(\frac{1}{2^n \|H_n\|_{C^n}}, \frac{1}{2^n q_n \|H_n\|_{C^1}})$,

then the conclusions of Lemma 4.8 hold.

Proof. Fix an arbitrary $z \in H_n(C_n)$. It follows from Remark 4.10 that for any element $\xi_{n,i} \in \xi_n$ there exists $m \leq q_{n+1}$ such that $H_n S_{\alpha_{n+1}}^m H_n^{-1}(z) \in H_n(\xi_{n,i})$. We claim that for some $\eta_n \rightarrow 0$ the collection $H_n(\xi_n)$ is η_n -dense in $H_n(C_n)$ in the sense that for any $z' \in H_n(C_n)$ there exists $z_i \in H_n(\xi_{n,i})$ where $\xi_{n,i} \in \xi_n$ such that $d(z_i, z') \leq \eta_n$: Indeed let r_n be such that $\lambda(B(r_n)) = 1/n$ then the fact that $\lambda(\bigcup H_n(\xi_{n,i})) \geq 1/n$ implies that any ball of radius r_n intersects an element of the collection $H_n(\xi_n)$. Our claim then follows from condition (2) of the lemma with $\eta_n = \max(r_n, \epsilon_n)$ and $H_n S_{\alpha_{n+1}} H_n^{-1}$ is (η_n, q_{n+1}) -minimal on $H_n(C_n)$. Finally, with this choice

of m_n Condition (3) matches with the corresponding condition in Lemma 4.8. \square

4.4. Construction of h_n and choice of α_{n+1} . We fix a sequence $\epsilon_n \rightarrow 0$ as $n \rightarrow \infty$. Now we assume that the sequence $H_l = h_l \circ \dots \circ h_1$ and α_{l+1} are constructed up to $l = n - 1$ and satisfy the conditions of Lemma 4.11 and we want to construct h_n and choose α_{n+1} such that the conditions of the lemma hold for $l = n$.

4.4.1. *Choice of the collection of strips ξ_n .* Define

$$\epsilon'_n := \frac{\epsilon_n}{\|H_{n-1}\|_{C^1}}. \quad (4.1)$$

We pick ν_n sufficiently small and consider a $(1/n, \nu_n)$ -collection of horizontal strips ξ_n of C_n such that $S_{\alpha_n}(\xi_n) = \xi_n$ and such that the measure of any strip in ξ_n is smaller than the measure of a ball with radius $\epsilon'_n/2$, i.e. $\lambda(\xi_{n,i}) \leq \lambda(B(\epsilon'_n/2))$. This requirement will be necessary in order to satisfy condition (4) in the next Proposition 4.12.

4.4.2. *Construction of h_n .* Define

$$\overline{C}_n := B(r_s + \frac{1}{n} + \frac{1}{n^3}) \times S^1.$$

Clearly, $C_n \subset \overline{C}_n \subset C_{n-1}$, and both inclusions are strict. Cf. Fig 4.1.

PROPOSITION 4.12. *There exists a diffeomorphism h_n of class C^∞ on $\mathbb{D}^{m-1} \times S^1$ such that*

1. h_n is volume preserving,
2. $h_n \circ S_{\alpha_n} = S_{\alpha_n} \circ h_n$,
3. $h_n \equiv \text{Id}$ outside \overline{C}_n ,
4. For any strip $\xi_{n,i} \in \xi_n$, $\text{diam}(h_n(\xi_{n,i})) \leq \epsilon'_n$.

Condition (2) can be satisfied since the collection ξ_n is invariant by S_{α_n} and (1) and (4) are compatible since we have imposed that $\lambda(\xi_{n,i}) \leq \lambda(B(\epsilon'_n/2))$.

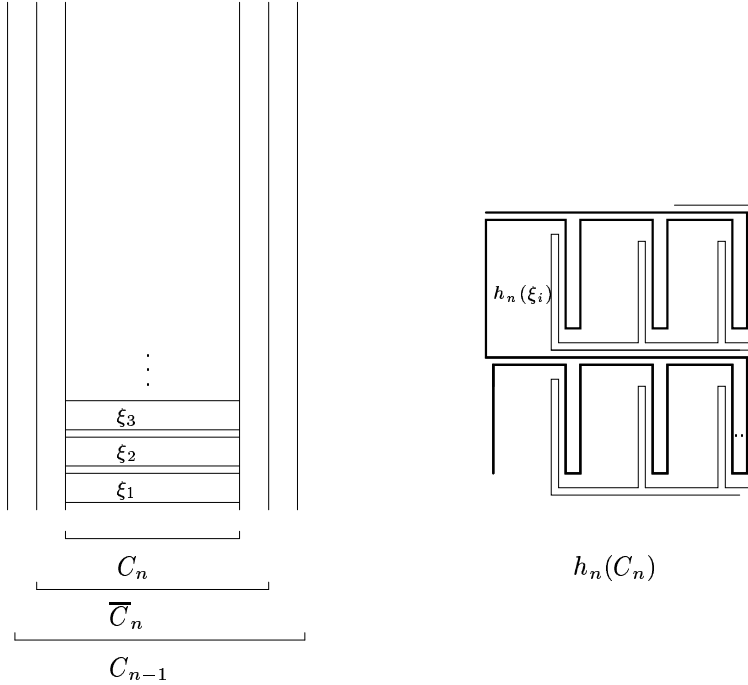

Fig. 4.1

4.4.3. *Checking the conditions of Lemma 4.11 and choice of α_{n+1} .* By (1) and (2) we can define the conjugating diffeomorphisms $H_n = h_1 \circ \dots \circ h_n$ as in (2.2) and (2.3). By definition of \overline{C}_n , (3) implies (1) of Lemma 4.11 while due to our choice of ϵ'_n in (4.1) Condition (4) implies (2) of Lemma 4.11.

Next, we choose $\alpha_{n+1} = p_{n+1}/q_{n+1}$ such that (3) in Lemma 4.11 is satisfied and such that $q_{n+1} \geq 1/\nu_n$ in order for the $(1/n, \nu_n)$ -collection ξ_n considered in §4.4.1 to be a $(1/n, 1/q_{n+1})$ -collection as required in Lemma 4.11.

All the conditions of Lemma 4.11 being satisfied by the sequences α_n and H_n thus constructed, the diffeomorphisms $H_n S_{\alpha_{n+1}} H_n^{-1}$ converge in the C^∞ topology to a diffeomorphism with a minimal set of measure s . \square

4.4.4. *Special choice of h_n and α_{n+1} .* As was mentioned in Section 2.2 the most natural way to ensure commutativity relation (2) in Proposition 4.12 is to take the fundamental domain $\Delta_n = \mathbb{D}^{m-1} \times [0, \frac{1}{q_n}]$, construct a volume preserving diffeomorphism g of Δ onto itself, identical near its boundary and satisfying conditions (3) and (4) and extend g by periodicity. It is also natural to choose q_{n+1} to be a multiple of q_n .

With these special choices one produces a nested sequence of partitions invariant under $H_n S_{\alpha_{n+1}} H_n^{-1}$, and hence by continuity under the limit diffeomorphism f . Those partitions are $H_n(\zeta_n)$ where ζ_n is simply the partition

into the “layers” $\mathbb{D}^{m-1} \times [\frac{k}{q_n}, \frac{k+1}{q_n}]$, $k = 0, \dots, q_n - 1$. These layers are simply images of the fundamental domain Δ_n under iterates of the rotation S_{α_n} . Restricted to the minimal set C this sequence of partitions become exhaustive in the measurable sense (converges to ϵ in the more customary terminology of ergodic theory) due to Lemma 4.11 and 4.12, (4). Notice also that on the boundaries of the partition elements the conjugacies H_n stabilize: For the boundary of ζ_n all h_m with $m > n$ are identities. This implies in particular that the set C contains a dense set of smooth $m - 1$ -dimensional discs $H_n(B(r_s)) \times \{\frac{k}{q_n}\}$, $n = 1, 2, \dots$; $k = 0, 1, \dots, q_n - 1$. For the purposes of the further discussion we will call the choice of h_n 's described above simply *special*.

4.5. Topological properties of the minimal set. Certain properties of the minimal set C constructed above are obvious. First, it is connected being the intersection of the nested sequence of connected sets $H_n(C_n)$. Furthermore, in the two-dimensional case $m = 2$ the complement to each set $H_n(C_n)$ to $\mathbb{D} \times S^1$ consists of two open connected components and this remains true for C . Each connected component of the complement is dense in C . For $m > 2$ the set $\mathbb{D}^{m-1} \times S^1 \setminus C$ is connected.

It follows immediately from our construction that the diffeomorphism f is C^∞ rigid, namely $F^{q_n} \rightarrow \text{Id}$ as $n \rightarrow \infty$ in the C^∞ topology. This allows us to address statement (2) of Theorem 4.1. We begin with dimension 2 where the statement follows directly from our construction without extra assumptions.

PROPOSITION 4.13. *If $m = 2$ the minimal set C has topological dimension one and for any $x \in C$ and any sufficiently small open neighborhood V of x , the intersection $C \cap V$ has topological dimension one and is not homeomorphic to the product of an interval with a Cantor set.*

Proof. Since the complement $\mathbb{D} \times S^1 \setminus C$ has two connected components no neighborhood in C can be totally disconnected and hence $C \cap V$ has topological dimension one.

Now assume $C \cap V$ is homeomorphic to $\mathbb{R} \times K$ where K is a Cantor set. By the Jordan Curve Theorem every copy of \mathbb{R} divides a certain small neighborhood of x in $\mathbb{D} \times S^1$ (not necessarily V itself) into two connected components. Hence every other copy of \mathbb{R} belongs to one of the components and hence the homeomorphism between $\mathbb{R} \times K$ and $C \cap V$ introduces an order in the Cantor set K . This implies that in $C \cap V$ there are intervals which are limits of other intervals from one side only; in fact only from a given side. Take such an interval I which corresponds to the point $x_0 \in K$. By rigidity $f^{q_n}I$ are intervals which for large n lie in $C \cap V$ (after possibly a slight truncation) and approach I . These intervals are connected components of $C \cap V$; hence they correspond to elements in K approaching x_0 . The order of the intervals $f^{q_n}I$ for every I in a given small neighborhood is the same, thus they approach I either from both sides or from the same side (call it “left”) with respect to the order. But there are intervals I which are limits

of others only from the other ("right") side. This contradiction rules out the product structure. \square

Thus we completed the proof of Theorem 4.1 for the two-dimensional case.

REMARK 4.14. Since a pseudo-circle does not contain any embedded topological arcs any set C obtained with a special choice of parameters as in Section 4.4.4 is different from those obtained by Handel [15] which are pseudocircles.

In the general case we do not see how to obtain a similar statement directly. It follows however with an extra assumption, namely by the special choice of the parameters of our construction described in Section 4.4.4.

PROPOSITION 4.15. *If the minimal set C contains a homeomorphic image of the disc \mathbb{D}^{m-1} (and hence has topological dimension $m - 1$) then for any $x \in C$ and any sufficiently small open neighborhood V of x , the intersection $C \cap V$ has topological dimension $m - 1$ and is not homeomorphic to the product of a disc with a Cantor set.*

Proof. After a few preliminary comments the proof becomes almost identical to the previous one. By minimality if there is a single homeomorphic image of \mathbb{R}^{m-1} , $I \subset C$ then there is a dense set of points belonging to such images. Hence any neighborhood of any point has topological dimension $m - 1$ and it cannot be homeomorphic to the product of a Cantor set with a disc of dimension less than $m - 1$. Assuming $C \cap V$ is homeomorphic to $\mathbb{R}^{m-1} \times K$ we argue as before. By the Jordan Theorem in dimension m there is an order among the copies of \mathbb{R}^{m-1} and hence there are some copies which are limits of others from a given side only. This contradicts rigidity of f . \square

4.6. Ergodic properties of the minimal set. The restriction of the diffeomorphism f to the minimal set C preserves the Lebesgue measure, or, more precisely, the absolutely continuous probability measure λ_C obtained by normalizing the restriction of the measure λ to C . Our construction guarantees unique ergodicity of f restricted to the set C . Furthermore, the special choice of parameters described in Section 4.4.4 makes (f, λ_C) metrically isomorphic to the rotation of the circle by the angle $\alpha = \lim_{n \rightarrow \infty} \alpha_n$ as in the construction of [1, Section 4]. On the other hand, one can choose parameters in a different way to make f weakly mixing with respect to λ_C . Other modifications are also possible, see [1].

On the other hand, by modifying our construction along the lines described in [38] one may violate unique ergodicity; for example make λ_C decompose into any given finite or countable number of ergodic components. Furthermore, one may modify our construction by making the transformations h_n not volume preserving in such a way that the minimal set will still have positive (and prescribed) Lebesgue measure but invariant measure(s) of f supported by the set C will be all singular or some of them will be

absolutely continuous and some singular. Presenting all these variations in detail will take too much space and will look rather tedious.

4.7. Further properties and open problems. While we have been able to exclude the Euclidean cross Cantor product structure in two-dimensional case as well as for any standard choice of parameters and thus demonstrate that our minimal sets are somewhat exotic some natural questions remain open. As with measure-theoretic properties it is possible that the answers may vary depending on the choice of parameters in the construction. For example we do not know whether any choice of parameters leads to a locally connected set or a path-connected set.

Notice that in Handel's construction [15] for the two-dimensional case the minimal set is a pseudo-circle and in particular is not locally connected. Handel's construction may be put into our framework to make the set of positive (and, in fact, given) measure. The main mechanism that makes the resulting set nontrivial in that construction is a twist of the standard fundamental domains along the orbits of the rotation rather than spreading the orbits within those domains as for special choices of parameters. Even with a special choice of parameters there is big freedom for relative position of cores which the image of an orbit of the circle action intersects. If one chooses those cores in a sufficiently "wild" way so that the images of successive parallelograms are far away one can guarantee that the minimal set C is not locally connected. It is not clear whether it is possible to achieve local connectedness of C by making more "tame" choices where images of successive parallelograms are usually close to each other so that the image of a vertical segment looks as an approximation of a Peano curve. Such a possibility looks fairly plausible. On the other hand, it looks unlikely that the minimal set C is ever path-connected.

More generally, there are still certain natural open questions about topological and ergodic properties of exotic minimal sets. It seems that in dimension ≥ 3 there is more freedom so we restrict ourselves to the two-dimensional case.

PROBLEM 4.16. Let C be a minimal set for a diffeomorphism f of a two-dimensional manifold M .

1. Can C be nowhere dense and path-connected?
2. Can C be locally homeomorphic to the product of the line and the Cantor set?
3. Can C carry a mixing invariant measure?

Notice that the last question is open both for nowhere dense invariant minimal sets and for minimal diffeomorphisms of \mathbb{T}^2 .

5. TRANSITIVE NON ERGODIC DIFFEOMORPHISMS.

Let f be a map on a complete separable metric space M . Denote by $\phi_f \subset M$ the set of points with dense orbit, i.e. $x \in \phi_f$ if and only if

$\overline{\{f^n(x)\}_{n \in \mathbf{Z}}} = M$. Recall that a map f is said to be topologically transitive (or simply transitive) if ϕ_f is not empty and in this case it is easy to see that ϕ_f is a G^δ dense set in M . When M is a Riemannian manifold it is natural to ask how small can the measure of ϕ_f be for a topologically transitive map f , especially in the case of a volume preserving map f . If such a map is ergodic then the set ψ_f has full measure. The same may be true for nonergodic maps [13]. We show in this section that the opposite can also be true. To build examples, we use an appropriately adjusted version of the approximation by conjugation method of Section 2.1.

THEOREM 5.1. *Let M be an m -dimensional differentiable manifold with a nontrivial circle action $\mathcal{S} = \{S_t\}_{t \in \mathbb{R}}$, $S_{t+1} = S_t$ preserving a smooth volume μ . There exists a C^∞ diffeomorphism f of M preserving μ such that f is transitive and $\mu(\phi_f) = 0$. Furthermore, f can be chosen arbitrary close to identity in the C^∞ topology.*

5.1. Reduction to the case of $[0, 1] \times \mathbb{T}^{m-1}$.

5.2. Construction of the diffeomorphism h_n . In this section we consider that the diffeomorphisms h_l were constructed up to $l = n - 1$ and that the rational $\alpha_n = p_n/q_n$ has been chosen.

DEFINITION 5.2. For every integer $n \geq 1$ and every integer $k \leq q_n - 1$ we define

$$\begin{aligned} B_{n,k}^r &= \left[\frac{1}{2} + \frac{k}{2q_n}, \frac{1}{2} + \frac{k+1}{2q_n} \right] \times \left[0, \frac{1}{q_n} \right], \\ B_{n,k}^l &= \left[\frac{1}{2} - \frac{k+1}{2q_n}, \frac{1}{2} - \frac{k}{2q_n} \right] \times \left[0, \frac{1}{q_n} \right], \\ I_{n,k}^r &= \left\{ \frac{1}{2} \right\} \times \left[\frac{k}{q_n^3} + \frac{1}{4q_n^3}, \frac{k}{q_n^3} + \frac{3}{4q_n^3} \right] \subset \left\{ \frac{1}{2} \right\} \times \left[0, \frac{1}{q_n^2} \right], \\ I_{n,k}^l &= \left\{ \frac{1}{2} \right\} \times \left[\frac{1}{q_n^2} + \frac{k}{q_n^3} + \frac{1}{4q_n^3}, \frac{1}{q_n^2} + \frac{k}{q_n^3} + \frac{3}{4q_n^3} \right] \subset \left\{ \frac{1}{2} \right\} \times \left[\frac{1}{q_n^2}, \frac{2}{q_n^2} \right]. \end{aligned}$$

For every integer $n \geq 1$ and for any $\rho_0 \in [0, 1]$ define

$$\begin{aligned} D_{\rho_0}^r &= \{(\rho, \theta) \in M / \rho_0 \leq \rho \leq 1, \theta \in \mathbb{T}\}, \\ D_{\rho_0}^l &= \{(\rho, \theta) \in M / 0 \leq \rho \leq \rho_0, \theta \in \mathbb{T}\}. \end{aligned}$$

Finally for any $n \geq 1$ define

$$M_n = [0, 1] \times \left[\frac{1}{q_n^{\frac{3}{2}}}, \frac{1}{q_n} \right].$$

PROPOSITION 5.3 (Properties of h_n). *For every integer $n \geq 1$, there exists a diffeomorphism h_n with the following properties*

1. h_n preserves μ ,
2. $h_n S_{\frac{1}{q_n}} = S_{\frac{1}{q_n}} h_n$,
3. $h_n \equiv \text{Id}$ on the set M_n , in particular $h_n(1/2, 0) = (1/2, 0)$,
4. For any $k \leq q_n - 1$, $h_n(I_{n,k}^j) \subset B_{n,k}^j$, $j = r, l$,
5. For any $\rho_0 > 1/n$ we have

$$h_n \left(D_{\frac{1}{2} + \rho_0}^r \right) \subset D_{\frac{1}{2} + \rho_0 - \frac{1}{2^n}}^r,$$

$$h_n \left(D_{\frac{1}{2} - \rho_0}^l \right) \subset D_{\frac{1}{2} - \rho_0 + \frac{1}{2^n}}^l.$$

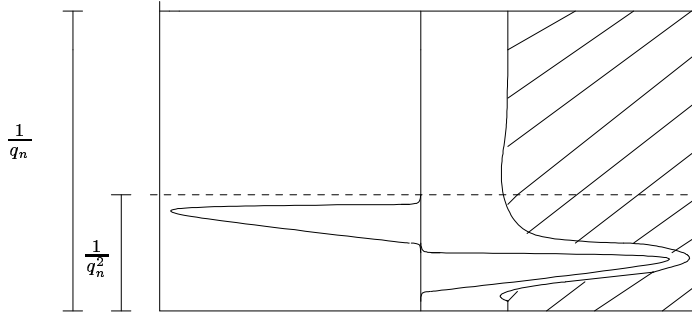

Fig 5.1. $h_n \left(\{\frac{1}{2}\} \times [0, \frac{1}{q_n}] \right)$ and $h_n(D_{\frac{1}{2} + \rho_0}^r)$.

5.3. **Choice of α_{n+1} and convergence.** As in the other sections we choose α_{n+1} to insure convergence of $f_n = H_n S_{\alpha_{n+1}} H_n^{-1}$ to a diffeomorphism f and have in addition that for any $m \leq q_{n+1}$

$$\|f_n^m - f^m\| \leq \frac{1}{n}. \quad (5.1)$$

5.4. **Transitivity.** In this paragraph we will prove that the limit diffeomorphism f is transitive. Specifically, we will prove that the orbit of the point $(1/2, 0)$ is dense.

DEFINITION 5.4. A map f of a separable metric space M is said to be ϵ -transitive if there exists $x \in M$ such that for any $y \in M$ there exists $l \in \mathbb{N}$ such that $d(f^l(x), y) \leq \epsilon$. If the above integer can be chosen less than some integer m independent of y we say that f is (ϵ, m) -transitive.

Clearly, a map f is transitive if and only if given any $\epsilon > 0$, f is ϵ -transitive. Hence from (5.1) to prove transitivity of f it is enough to prove that $f_n = H_n S_{\alpha_{n+1}} H_n^{-1}$ is $(1/n, q_{n+1})$ -transitive on M .

DEFINITION 5.5. Given a point $(\rho, \theta) \in M$ we define $O_{f,m}(\rho, \theta) = \{(\rho, \theta), \dots, f^{m-1}(\rho, \theta)\}$. A set $O \subset M$ is said to be ϵ -dense in M if given any $y \in M$ there exists $x \in O$ such that $d(x, y) \leq \epsilon$.

5.4.1. *The orbit of $(1/2, 0)$ under f_n .* With our definitions transitivity will follow if we prove that the set $O_{f_n, q_{n+1}}(1/2, 0)$ is $1/n$ -dense.

The following is evident if in our choice of α_{n+1} we require that $q_{n+1} \geq q_n^4$: For any $0 \leq p \leq q_n - 1$ and any $0 \leq k \leq q_n - 1$ and for $j = l$ and $j = r$ there exists an integer $m(p, k, j) \leq q_{n+1}$ such that

$$\{m\alpha_{n+1}\} \in S_{\frac{p}{q_n}}(I_{n,k}^j).$$

Since $H_n(1/2, 0) = (1/2, 0)$ we have that

$$\begin{aligned} f_n^{m(p,k,j)}(1/2, 0) &\in H_n S_{\frac{p}{q_n}}(I_{n,k}^j), \\ &= H_{n-1} h_n S_{\frac{p}{q_n}}(I_{n,k}^j) \\ &= H_{n-1} S_{\frac{p}{q_n}} h_n(I_{n,k}^j) \quad \text{from (2) of Lemma 5.3,} \\ &\subset H_{n-1} S_{\frac{p}{q_n}}(B_{n,k}^j) \quad \text{from (4) of Lemma 5.3.} \end{aligned}$$

In conclusion, we proved that for any $0 \leq p \leq q_n - 1$ and any $0 \leq k \leq q_n - 1$, for $j = l$ and $j = r$ there exists an integer $m(p, k, j) \leq q_{n+1}$ such that

$$f_n^{m(p,k,j)}(1/2, 0) \in H_{n-1} S_{\frac{p}{q_n}}(B_{n,k}^j).$$

Assuming that $\|H_{n-1}\|_{C^1} \leq \frac{q_n}{n}$ we have that $\text{diam}(H_{n-1} S_{p/q_n}(B_{n,k}^j)) \leq 1/n$ hence the partition $\{H_{n-1} S_{p/q_n}(B_{n,k}^j)\}$, $0 \leq p \leq q_n - 1$, $0 \leq k \leq q_n - 1$, $j = l, r$, is a $1/n$ grid of M . Therefore the set $O_{f_n, q_{n+1}}(1/2, 0)$ is indeed $(1/n)$ -dense in M and the proof of transitivity is complete. \square

5.5. **Non ergodicity:** $\mu(\phi_f) = 0$.

5.5.1. *Preliminary.* As a consequence of Property (5) of Lemma 5.3 we get the following properties on the diffeomorphism $H_n = h_1 \circ \dots \circ h_n$

COROLLARY 5.6. *For any $\rho_0 > 0$ there exists $n(\rho_0)$ such that for any $n \geq n(\rho_0)$ we have*

$$\begin{aligned} H_n(D_{\frac{1}{2}+\rho_0}^r) &\subset H_{n(\rho_0)}(D_{\frac{1}{2}+\frac{\rho_0}{2}}^r), \\ H_n(D_{\frac{1}{2}-\rho_0}^l) &\subset H_{n(\rho_0)}(D_{\frac{1}{2}-\frac{\rho_0}{2}}^l). \end{aligned}$$

Proof. Fix $\rho_0 > 0$ and let $n(\rho_0) \geq 4$ be such that $\rho_0 \geq 2/n(\rho_0)$.

For $n \geq n(\rho_0)$ we have that $1/n < \rho_0$ hence by Property (5) of Lemma 5.3

$$h_n\left(D_{\frac{1}{2}+\rho_0}^r\right) \subset D_{\frac{1}{2}+\rho_0-\frac{1}{2^n}}^r,$$

and if $n-1 \geq n(\rho_0)$ we have $1/(n-1) \leq 1/n(\rho_0) < \rho_0 - 1/2^n$ hence

$$h_{n-1} h_n\left(D_{\frac{1}{2}+\rho_0}^r\right) \subset D_{\frac{1}{2}+\rho_0-\frac{1}{2^n}-\frac{1}{2^{n-1}}}^r.$$

Since for any $l \geq n(\rho_0)$ we have $\rho_0 - 1/2^n - \dots - 1/2^l \geq \rho_0 - 1/2^{n(\rho_0)-1} \geq \rho_0/2 \geq 1/n(\rho_0)$ we can continue inductively and obtain that

$$h_{n(\rho_0)+1} \circ \dots \circ h_n \left(D_{\frac{1}{2}+\rho_0}^r \right) \subset D_{\frac{1}{2}+\frac{\rho_0}{2}}^r$$

which implies the conclusion of the corollary, the case of $D_{\frac{1}{2}-\rho_0}^l$ being similar. \square

5.5.2. *Proof of $\mu(\phi_f) = 0$.* We introduce the following set

$$E_l = \{(\rho, \theta) \in M/\rho \neq \frac{1}{2} \text{ and for any } n \geq l+1, h_n(x) = x\}.$$

From Property (3) in Lemma 5.3 we have that

$$\begin{aligned} \mu(E_l) &\geq 1 - \frac{1}{\sqrt{q_{l+1}}} - \frac{1}{\sqrt{q_{l+2}}} - \dots \\ &\geq 1 - \frac{2}{\sqrt{q_{l+1}}}. \end{aligned}$$

Since H_l is measure preserving we also have $\mu(H_l(E_l)) \geq 1 - 2/\sqrt{q_{l+1}}$. We will hence finish if we show that for any point $z \in H_l(E_l)$ the orbit of z under f is not dense in M . From the convergence condition (5.1) in §5.3 it suffices to prove that there exists a fixed closed set $D(z)$ strictly included in M such that for any n , $O_{f_n, q_{n+1}}(z) \in D(z)$.

Fix $z \in H_l(E_l)$ and write $z = H_l(z')$. We can assume that for some $\rho_0 > 0$, $z' \in E_l \cap D_{1/2+\rho_0}^r$, the other case $z' \in E_l \cap D_{1/2-\rho_0}^l$ being similar.

For any $n \geq l$ and any $m \leq q_{n+1}$ we have that $f_n^m(z) = H_n S_{\alpha_{n+1}}^m(z')$. Since $S_{\alpha_{n+1}}^m(z') \in D_{1/2+\rho_0}^r$, Corollary 5.6 implies that for any $n \geq n(\rho_0)$ we have $f_n^m(z) \in H_{n(\rho_0)} D_{1/2+\rho_0/2}^r$. The latter being a fixed closed set strictly included in M the proof is complete. \square

6. MIXING FLOWS ON MANIFOLDS ADMITTING A NONTRIVIAL \mathbb{T}^3 ACTION.

All the constructions we have presented up to now share the property of being C^∞ rigid, namely that the limit diffeomorphism F satisfies $F^{q_n} \rightarrow \text{Id}$ as $n \rightarrow \infty$ in the C^∞ topology for some sequence of integers q_n . This is also the case for all the available constructions following the approximation by conjugation method introduced in [1]. It is an open problem whether there exist a circle action \mathcal{S} on a compact manifold and α such that the corresponding space \mathcal{A}_α contains a nonrigid transformation. This would be a first step towards proving the existence of mixing maps in \mathcal{A}_α (Cf. Problem 2.2). The situation is different if we consider higher dimensional actions. Indeed, it was proved in [6] that there exist on \mathbb{T}^3 linear flows that can be made mixing via smooth (real analytic) reparametrization, and reparametrizations of linear flows are by nature in the closure of conjugacies of periodic linear flows on \mathbb{T}^3 . The latter is an immediate consequence of the density of Diophantine

frequencies and of the fact that any smooth reparametrization of a Diophantine linear flow is smoothly conjugated to a linear flow. In this section, given a manifold M admitting a nontrivial smooth \mathbb{T}^3 action preserving a smooth volume μ we construct μ -mixing diffeomorphisms in the closure of conjugacies of elements of the action. To this end we combine the techniques of reparametrization of linear flows on \mathbb{T}^3 with the explicit approximation by conjugation methods. Besides working with higher dimensional actions and requiring a control for *all iterates* of the limit diffeomorphism, the main difference with the former sections is that we need to work in restricted spaces \mathcal{A}_α with special Liouvillean vectors $\alpha \in \mathbb{R}^3$ chosen *a priori* such that the linear flow $R_{t\alpha}$ admits smooth mixing reparametrizations. Conditions of the type 2.4 become more restrictive since we do not have complete freedom in the choice of the periodic approximations of α and explicit bounds on the conjugations used are required. This corresponds to quantitative versions of the approximation by conjugation method similar to the approach of [11].

6.1. Formulation of results.

THEOREM 6.1. *Assume M is a differentiable manifold admitting a nontrivial smooth \mathbb{T}^3 action $\mathcal{S} = \{S_v\}_{v \in \mathbb{R}^3}$, $S_{v+k} = S_v$ if $k \in \mathbb{Z}^3$ and let μ be a smooth volume preserved by \mathcal{S} . Then there exists a sequence $\gamma_n \in \mathbb{Q}^3$ and a sequence H_n of diffeomorphisms preserving μ such that the sequence $H_n S_{t\gamma_n} H_n^{-1}$ converges in the C^∞ topology to a flow preserving μ and mixing for this measure.*

REMARK 6.2. This is the optimal result for flows, and on manifold with a \mathbb{T}^2 nontrivial action one expects that considering successive conjugations of some sequence of rational elements of the action it should be possible to obtain a mixing diffeomorphisms in the limit. Not even on \mathbb{T}^2 we are able to provide a construction.

6.2. Reduction to $\mathbb{T}^3 \times \mathbb{D}^m$.

Theorem 6.1 will follow if we can prove it in the particular case of a direct product $\mathbb{T}^3 \times \mathbb{D}^m$ with successive conjugacies H_n having compact support in the interior of $\mathbb{T}^3 \times \mathbb{D}^m$.

6.3. Plan of the construction. We will use the natural \mathbb{T}^3 action on $\mathbb{T}^3 \times \mathbb{D}^m$ $S_v(\theta, r) = (\theta + v, r)$. We will not directly construct the mixing flow as a limit of conjugacies of periodic flows $H_n S_{t\gamma_n} H_n^{-1}$. Instead we will use successive conjugacies of a flow $T^t \times \text{Id}_{\mathbb{D}^m}$ where T^t is the mixing flow on \mathbb{T}^3 obtained in [6] via reparametrization of a Liouvillean linear flow on \mathbb{T}^3 . Theorem 6.1 then follows since reparametrizations of linear flows are in the closure of conjugacies of periodic linear flows on \mathbb{T}^3 .

6.4. Mixing reparametrizations of linear flows. Since some specific features of the mixing reparametrized flow constructed in [6] will be needed in the proof of Theorem 6.1 we will summarize in this section the construction and mention the properties that will be useful for the sequel.

6.4.1. *Notations and definitions.* For $\alpha \in \mathbb{R}^3$, we denote by R_α^t the linear flow on the torus \mathbb{T}^3 given by $d\theta/dt = \alpha$, where $\theta \in \mathbb{T}^3$. For a continuous function $\phi: \mathbb{T}^3 \rightarrow \mathbb{R}_+^*$ we denote by $R_{\alpha,\phi}^t$ the reparameterized flow given by $d\theta/dt = \phi(\theta)\alpha$. If the coordinates of α are rationally independent then the linear flow R_α^t is uniquely ergodic and so is the reparameterized flow that preserves the measure with density $1/\phi$. In contrast, other properties of the linear flow such as mixing may be very sensitive to reparameterizations. The reparameterized flow $R_{\alpha,\phi}^t$ can be viewed as a special flow $T_{\alpha,\phi}^t$ over R_α and under φ where α this time is an \mathbb{R}^2 vector and φ is a strictly positive function over \mathbb{T}^2 . We denote by $M_{\alpha,\varphi}$ the space where the special flow acts which is obtained as a quotient of $\mathbb{T}^2 \times \mathbb{R}$ by the equivalence relation $(x, s + \varphi(x)) \sim (x + \alpha, s)$ and that can be identified with \mathbb{T}^3 . Conversely any smooth special flow $T_{\alpha,\phi}^t$ can be viewed as a reparameterization of some linear flow on \mathbb{T}^3 . Henceforth, we will only work with special flows that are easier to manipulate than reparameterizations. The unique probability measure preserved by the special flow is given by the product of the Haar measure on the base \mathbb{T}^2 and the Lebesgue measure on the fibers normalized by the mean value of φ . The k -dimensional Lebesgue measures will be denoted by $\lambda^{(k)}$.

6.4.2. *Mixing special flows over a translation of \mathbb{T}^2 .* Our choice of the translation $R_{\alpha,\alpha'}$ and the ceiling function φ follows [40]. We take $(\alpha, \alpha') \in \mathbb{R}^2 - \mathbb{Q}^2$, such that their sequences of best approximations q_n and q'_n satisfy for any $n \geq n_0(\alpha, \alpha')$

$$q'_n \geq e^{4q_n}, \quad (6.1)$$

$$q_{n+1} \geq e^{4q'_n}. \quad (6.2)$$

The ceiling function we will consider is the following strictly positive real analytic function on \mathbb{T}^2 :

$$\varphi(x, y) = 1 + \operatorname{Re} \left(\sum_{k=2}^{\infty} \frac{e^{i2\pi kx}}{e^k} + \sum_{k=2}^{\infty} \frac{e^{i2\pi ky}}{e^k} \right). \quad (6.3)$$

In [6] it was proved that

THEOREM 6.3. *Under conditions (6.1)–(6.3), the special flow $T_{\alpha,\alpha',\varphi}^t$ is mixing for its unique invariant probability measure.*

Since α, α' and φ are fixed, to alleviate the notations we will denote by T^t the special flow $T_{\alpha,\alpha',\varphi}^t$ and by M the space $M_{\alpha,\alpha',\varphi}$. We will need the following properties of T^t , the first one of which is an obvious approximation of the flow by special flows over periodic translations and the other being a refinement of the mixing property that can be derived from the proof of mixing given in [6].

We will denote by α_n and α'_n the n -th convergents of α and α' , i.e. $\alpha_n = p_n/q_n$, $\alpha'_n = p'_n/q'_n$. By T_n^t we denote the special flow over the periodic

translation R_{α_n, α'_n} and under the function φ . Since $|\alpha - \alpha_n| \leq 1/q_n q_{n+1}$ and $|\alpha' - \alpha'_n| \leq 1/q'_n q'_{n+1}$ we deduce

$$\|T^t - T_n^t\| = O\left(\frac{t}{q_n q_{n+1}}\right). \quad (6.4)$$

The specialized mixing property of T^t . Let $\delta_n = 1/q_n$. Consider a collection $\mathcal{C}_n = \{C_{n,j}\}_{j \leq M_n}$ of disjoint sets in M of the form

$$C_{n,j} = \left[\frac{i}{q_n}, \frac{i+1}{q_n}\right] \times \left[\frac{i'}{q'_n}, \frac{i'+1}{q'_n}\right] \times [s, s + \delta_n]$$

for some $i = i_j \leq q_n - 1$ and $i' = i'_j \leq q'_n - 1$ and $s = s_j$ satisfying

$$s + \delta_n \leq \min_{(x, x') \in [i_j/q_n, (i_j+1)/q_n] \times [i'_j/q'_n, (i'_j+1)/q'_n]} \varphi(x, x').$$

We take the collection \mathcal{C}_n such that $\mu(\bigcup C_{n,j}) \geq 1 - \epsilon_n$ with $\epsilon_n = O(1/q_n)$.

DEFINITION 6.4. An ϵ -grid of a set (A, μ) is any partition of A into disjoint measurable sets of diameter less than ϵ . An ϵ -grid of a collection of disjoint similar sets $\{C_j\}_{j \leq M}$ is given by some ϵ -grid of C_1 identically repeated inside each C_j , $j \leq M$.

DEFINITION 6.5. For a pair of strictly positive numbers (ϵ, η) , a set $B \subset A$ is said to be (ϵ, η) -uniformly-distributed inside A if there exists an ϵ -grid of A such that for each atom A_k of the grid we have

$$\left| \frac{\mu(B \cap A_k)}{\mu(B)} - \frac{\mu(A_k)}{\mu(A)} \right| \leq \eta \frac{\mu(A_k)}{\mu(A)}.$$

must replace μ by its conditional on B in $\mu(B)$ and $\mu(B \cap A_k)$ and by its conditional on A .

DEFINITION 6.6. For a pair of strictly positive numbers (u, v) , a set B is said to be (u, v) -identically-distributed in a collection of disjoint similar sets $\{C_j\}_{j \leq M}$ if there exists a u -grid of the collection $\{C_j\}_{j \leq M}$ such that for every pair $j, j' \leq M$ and for any $k \leq K$ (K referring to the number of atoms inside each C_j), we have

$$\left| \mu(B \cap C_{j,k}) - \mu(B \cap C_{j',k}) \right| \leq v \mu(B \cap C_{j,k}).$$

REMARK 6.7. In the above definition, the measurable sets B , A , A_k , $C_{j,k}$ might be of different dimensions and μ should be replaced when necessary by its appropriate conditionals.

REMARK 6.8. A set B that is (u, v) -identically-distributed inside the collection $\mathcal{C}_n = \{C_{n,j}\}_{j \leq M_n}$ is $(2/q_n, v)$ -uniformly-distributed in M (this is due to the fact that the diameter of the sets $C_{n,j}$ is less than $2/q_n$). Moreover, because each set $C_{n-1,j}$ is almost a union of sets of \mathcal{C}_n then $B \cap C_{n-1,j}$ is $(2/q_n, 2v)$ -uniformly distributed inside $C_{n-1,j}$.

The specific mixing property of T^t that will be crucial in the sequel is the following

PROPOSITION 6.9. *Let ξ_n be a set in $M_{\alpha,\varphi}$ of the form $I \times J \times \{s\}$ where I and J are intervals of size $1/e^{q'_n}$. Then for any $t \geq e^{3q'_n}$ we have that $T^t \xi_n$ is $(1/e^{q'_n}, 1/n^2)$ -identically-distributed in the collection $\mathcal{C}_n = \{C_{n,j}\}_{j \leq M_n}$.*

6.5. The successive conjugations scheme. We will use the same notation T^t and T_n^t to indicate the special flows over $T_{\alpha,\alpha',\varphi}^t$ and $T_{\alpha_n,\alpha'_n,\varphi}^t$ as well as the flows $T^t \times \text{Id}_{\mathbb{D}^m}$ and $T_n^t \times \text{Id}_{\mathbb{D}^m}$. For $r \in (0, 1]$, we denote by $D(0, r)$ the closed disc of radius r inside \mathbb{D}^m . The general scheme of the construction is the following: We construct volume preserving diffeomorphisms h_n compactly supported on $M_{\alpha_n,\alpha'_n,\varphi} \times \mathbb{D}^m$ of the form

$$h_n(x, x', s, r) = (x, x', s, g_{n,x,x'}(r)) \quad (6.5)$$

where for each $(x, x') \in \mathbb{T}^2$ $g_{n,x,x'}$ is a compactly supported volume preserving diffeomorphism of \mathbb{D}^m satisfying

$$g_{n,x,x'}(r) = g_{n,x+\alpha_n,x'+\alpha'_n}(r) \quad (6.6)$$

for all (x, x', r) . This implies that h_n commutes with T_n^t . We can choose $g_{n,x,x'}$ increasingly sensitive with respect to x and x' but in a controlled as follows

PROPOSITION 6.10. *It is possible to construct the diffeomorphism h_n as in (6.5)–(6.6) such that the following holds*

1. h_n is volume preserving and compactly supported,
2. $h_n T_n^t = T_n^t h_n$,
3. For any $l \in \mathbb{N}$, for n large enough $\|h_n\|_{C^l} \leq e^{\frac{1}{2}\sqrt{q'_n}}$.
4. For any $r \in D(0, 1 - e^{-n}) \subset \mathbb{D}^m$, for any $j \leq M_n$ we have that $h_n(C_{n,j} \times \{r\})$ is $(e^{-q'_n-1}, \frac{1}{n})$ -uniformly-distributed inside $C_{n,j} \times \mathbb{D}^m$.
diameter less than $e^{-q'_n-1}$ such that for any atom D of the partition we have $\bigcap(C_{n,j} \times D) - \lambda(3)(C_{n,j})\lambda^{(m)}(D) \leq \frac{1}{n}\lambda^{(3)}(C_{n,j})\lambda^{(m)}(D)$.

We now consider the flows T^t , T_n^t and the diffeomorphisms h_n as flows and diffeomorphisms on $M \times \mathbb{D}^m$ and define $H_n = h_1 \circ \dots \circ h_n$ and consider the sequence $H_n T^t H_n^{-1}$.

From the above proposition we can easily deduce the following properties of H_n

PROPOSITION 6.11. *The diffeomorphisms H_n are compactly supported in the interior of $M \times \mathbb{D}^m$ and satisfy*

1. H_n is volume preserving,
2. For any $l \in \mathbb{N}$, for n large enough $\|H_n\|_{C^l} \leq e^{\sqrt{q'_n}}$,
3. For any $z \in D(0, 1 - e^{-n}) \subset \mathbb{D}^m$, for any $j \leq M_n$ we have that $H_n(C_{n,j} \times \{z\})$ is $(e^{-\frac{1}{2}q'_n-1}, 1/n)$ -uniformly-distributed inside $C_{n,j} \times \mathbb{D}^m$.

PROOF. Property (2) follows from (3) of Proposition 6.10. Property (3) then follows from (4) of Proposition 6.10 applied to h_n and from (1) and (2) of Proposition 6.11 applied to H_{n-1} . \square

6.6. Convergence and approximation.

PROPOSITION 6.12. *The sequence of flows $H_n T^t H_n^{-1}$ converges in the C^∞ topology to a volume preserving flow \overline{T}^t of $M \times \mathbb{D}^m$. Moreover, for $t \in [e^{3q'_n}, e^{3q'_{n+1}}]$ and $l \in \mathbb{N}$ we have for n large enough*

$$\|H_n T^t H_n^{-1} - \overline{T}^t\|_{C^l} \leq \frac{1}{2^n}.$$

PROOF. From (2) of Proposition 6.10 we have that

$$H_{n+1} T_{n+1}^t H_{n+1}^{-1} = H_n T_{n+1}^t H_n^{-1},$$

hence

$$\|H_n T^t H_n^{-1} - H_{n+1} T_{n+1}^t H_{n+1}^{-1}\|_{C^l} \leq \psi_n + \psi'_n$$

where

$$\begin{aligned} \psi_n &= \|H_n T^t H_n^{-1} - H_n T_{n+1}^t H_n^{-1}\|_{C^l}, \\ \psi'_n &= \|H_{n+1} T_{n+1}^t H_{n+1}^{-1} - H_{n+1} T^t H_{n+1}^{-1}\|_{C^l}, \end{aligned}$$

hence from (6.4) and (2) of Proposition 6.11 we conclude that

$$\|H_n T^t H_n^{-1} - H_{n+1} T_{n+1}^t H_{n+1}^{-1}\|_{C^l} = o\left(\frac{e^{q'_{n+1} t}}{q_{n+1} q_{n+2}}\right).$$

Since $q_{n+2} \geq e^{4q'_{n+1}}$ the proposition follows. \square

6.7. Proof of mixing.

It remains to prove the following

PROPOSITION 6.13. *The volume preserving flow of $M \times \mathbb{D}^m$*

$$\overline{T}^t = \lim_{n \rightarrow \infty} H_n T^t H_n^{-1}$$

is mixing.

The following is an almost straightforward Fubini argument

LEMMA 6.14. *and R are open balls in \mathbb{D}^m and \mathbb{T}^2 and $\delta \leq c$,*

If there is a sequence of measurable collections of subsets of $M \times \mathbb{D}^m$, $\{\mathcal{P}_t\}$ satisfying the following

$$\{\mathcal{P}_t\} \xrightarrow[t \rightarrow \infty]{} \varepsilon \quad (\text{partition into points}),$$

and such that for any open set $A \subset M \times \mathbb{D}^m$ and any $\varepsilon > 0$, there exists t_0 such that for $t > t_0$ we have for every atom $P_t \in \{\mathcal{P}_t\}$

$$\left| \mu\left(P_t \cap \overline{T}^{-t}(A)\right) - \mu(P_t)\mu(A) \right| \leq \varepsilon \mu(P_t), \quad (6.7)$$

then the flow \overline{T}^t is mixing.

REMARK 6.15. The atoms of the collection $\{\mathcal{P}_t\}$ might have positive codimension and the Lemma remains valid if appropriate conditional measures are used in (6.7).

Choice of the collection \mathcal{P}_t . Let $t \in \mathbb{R}_+$ and take n such that $t \in [e^{3q'_n}, e^{3q'_{n+1}}]$. We first consider a collection \mathcal{U}_n converging to the point partition in $M_{\alpha,\varphi} \times \mathbb{D}^3$ consisting of sets of the form $\xi \times \{s, r\}$ where ξ is a square on \mathbb{T}^2 with side $1/e^{q'_n}$. Since the diffeomorphism $h_n T^t$ is volume preserving we remain with a collection converging to the point partition if we discard the elements $\xi \times \{s, r\}$ that do not satisfy

$$\lambda^{(2)} \left[(\xi \times \{s, r\}) \cap T^{-t} h_n^{-1} (M_{\alpha,\varphi} \times D(0, 1 - e^{-(n-1)})) \right] \geq (1 - \frac{1}{n}) \lambda^{(2)}(\xi) \quad (6.8)$$

Finally, we consider the collection \mathcal{P}_t whose atoms are the sets $H_n(\xi \times \{s, r\})$ where $\xi \times \{s, z\}$ is as above. Due to the fact that $\|H_n\|_{C^1} \leq e^{\sqrt{q'_n}}$ we have that \mathcal{P}_t converges to the partition into points of $M_{\alpha,\varphi} \times \mathbb{D}^m$ as t goes to infinity.

Fix an open set $A \subset M \times \mathbb{D}^m$ and $\varepsilon > 0$. We finish if we check (6.7) of Lemma 6.14 for the elements of \mathcal{P}_t as $t \in [e^{3q'_n}, e^{3q'_{n+1}}]$ goes to infinity or equivalently as $n \rightarrow \infty$. To have (6.7) for this range of t , we are reduced in light of Proposition 6.12 to proving that for n large enough

$$\left| \lambda^{(2)} \left(\xi \times \{s, r\} \cap T^{-t} H_n^{-1}(A) \right) - \lambda^{(2)}(\xi) \mu(A) \right| \leq \varepsilon \lambda^{(2)}(\xi) \quad (6.9)$$

where ξ is a square in \mathbb{T}^2 of side $1/e^{q'_n}$ and $\xi \times \{s, r\}$ satisfies (6.8).

Since the collection $\mathcal{C}_{n-1} = \{C_{n-1,j}\}_{j \leq M_{n-1}}$ converges to the point partition, (6.9) will follow if for an arbitrary measurable set $D \subset \mathbb{D}^m$ we prove that for n large enough we have for any $j \leq M_{n-1}$

$$\left| \lambda^{(2)} \left(\xi \times \{s, r\} \cap T^{-t} H_n^{-1}(C_{n-1,j} \times D) \right) - \lambda^{(2)}(\xi) \lambda^{(3)}(C_{n-1,j}) \lambda^{(m)}(D) \right| \leq \varepsilon \lambda^{(2)}(\xi) \lambda^{(3)}(C_{n-1,j}). \quad (6.10)$$

Having fixed t and the atom $\xi \times \{s, r\} \in \mathcal{P}_t$ we set

$$U := h_n (T^t(\xi \times \{s, r\}))$$

and denote by $\tilde{\lambda}^{(2)}$ the measure $(h_n T^t)_* (\lambda^{(2)})$.

The equation we have to establish (6.10) becomes

$$\left| \tilde{\lambda}^{(2)} \left(U \cap H_{n-1}^{-1}(C_{n-1,j} \times D) \right) - \tilde{\lambda}^{(2)}(U) \lambda^{(3)}(C_{n-1,j}) \lambda^{(m)}(D) \right| \leq \varepsilon \tilde{\lambda}^{(2)}(U) \lambda^{(3)}(C_{n-1,j}). \quad (6.11)$$

From Proposition 6.9 we recall that since $t \geq e^{3q'_n}$ then

$$\text{The set } T^t \xi \times \{s\} \text{ is } (1/e^{q'_n}, 1/n^2) \text{ - identically-distributed in } \mathcal{C}_n. \quad (6.12)$$

We can carry this fact to U in the following way

Claim. There exists a partition of \mathbb{D}^m in open sets of diameter less than $1/e^{\frac{1}{2}q'_n}$, $\mathbb{D}^m = \bigcup_{l=1}^{L_n} D_l$, such that for each $l \leq L_n$, the set $U_l := U \cap (M \times D_l)$

is $(1/e^{\frac{1}{2}q'_n}, 1/n)$ -identically-distributed in the collection $\{C_{n,j} \times D_l\}_{j \leq M_n} \subset M \times \mathbb{D}^m$.

It is easy to see that the claim follows from (6.12) and two properties in the construction of h_n : The first is that according to (6.5) and (6.6) we have that for any $j, j' \leq M_n$ $h_n|_{C_{n,j} \times \mathbb{D}^m} \equiv h_n|_{C_{n,j'} \times \mathbb{D}^m}$; the second is that $\|h_n\|_{C^1} \leq e^{\sqrt{q'_n}}$ by Proposition 6.10.

than $1/e^{\frac{1}{2}q'_n}$, $\mathbb{D}^m = \bigcup_{l=1}^{L_n} D_l$ such that U is $(1/e^{\frac{1}{2}q'_n}, 2/n)$ -identically-distributed in the collection $\{C_{n,j} \times D_l\}_{j \leq M_n}$,

From Remark 6.8 the above claim implies that the set U_l is $(2/q_n, 1/n)$ -uniformly-distributed in $M \times D_l$ and more specifically that for any $j \leq M_{n-1}$ the set $U_l \cap (C_{n-1,j} \times D_l)$ is $(2/q_n, 2/n)$ -uniformly-distributed in the set $C_{n-1,j} \times D_l$.

The claim also implies that for any $j \leq M_{n-1}$

$$\begin{aligned} & \left| \tilde{\lambda}^{(2)} \left(U_l \cap (C_{n-1,j} \times D_l) \right) - \tilde{\lambda}^{(2)}(U_l) \lambda^{(3)}(C_{n-1,j}) \right| \\ & \leq \frac{3}{n} \tilde{\lambda}^{(2)}(U_l) \lambda^{(3)}(C_{n-1,j}) \end{aligned} \quad (6.13)$$

From (6.8) we have that

$$U \sim \bigcup_{D_l \subset D(0, 1 - e^{-(n-1)})} U_l \quad (6.14)$$

in the sense that the ratio between the measures of the left hand side set and the right hand side set converges to 1 as n goes to ∞ . So we assume l is such that $D_l \subset D(0, 1 - e^{-(n-1)})$. Property (3) in Proposition 6.11 and the fact that $\|H_{n-1}\|_{C^1} \leq e^{\sqrt{q_{n-1}}}$, together with its $(2/q_n, 2/n)$ -uniform distribution of the set $U_l \cap (C_{n-1,j} \times D_l)$ in the set $C_{n-1,j} \times D_l$ and (6.13) then imply that given the measurable set $D \in \mathbb{D}^m$ and $\varepsilon > 0$ we have for n large enough

$$\begin{aligned} & \tilde{\lambda}^{(2)} \left[\left(U_l \cap (C_{n-1,j} \times D_l) \right) \cap H_{n-1}^{-1}(C_{n-1,j} \times D) \right] \\ & \sim \tilde{\lambda}^{(2)} \left(U_l \cap (C_{n-1,j} \times D_l) \right) \lambda^{(m)}(D), \sim \tilde{\lambda}^{(2)}(U_l) \lambda^{(3)}(C_{n-1,j}) \lambda^{(m)}(D). \end{aligned} \quad (6.15)$$

From (6.5) we have that

$$H_{n-1} U \cap (C_{n-1,j} \times D) = H_{n-1} \left(U \cap (C_{n-1,j} \times \mathbb{D}^m) \right) \cap (C_{n-1,j} \times D)$$

hence having (6.14) in mind we can sum in (6.15) over l such that $D_l \subset D(0, 1 - e^{-(n-1)})$ and get

$$\tilde{\lambda}^{(2)} \left(H_{n-1} U \cap (C_{n-1,j} \times D) \right) \sim \tilde{\lambda}^{(2)}(U) \lambda^{(3)}(C_{n-1,j}) \lambda^{(m)}(D).$$

This gives equation (6.11) and the proof of mixing is hence accomplished. \square

7. OTHER DIRECTIONS AND MORE OPEN PROBLEMS

We discuss two areas where some of the most interesting and challenging problems related to the approximation by conjugation method appear: analytic constructions and the problem of smooth realization.

7.1. Real-analytic constructions. The approximation by conjugation method is a major source of constructing examples of smooth dynamical systems with prescribed ergodic or topological properties; other methods are skew products and time-changes. In the latter two cases, and except for some special exotic constructions [10], there is usually not much difference between the cases of sufficiently high finite differentiability and real analyticity. Constructions in [13], [24, Sections 12.3, 12.4, 13.3,13.4], [6, 7, 8, 9] provide typical examples. In a somewhat crude way this can be explained by essential linearity of the time change and skew product constructions. The conjugation by approximation construction is essentially nonlinear and it is based on convergence of maps obtained from certain standard maps by wildly diverging conjugacies.

Here a great difference between the differentiable and real analytic maps becomes apparent. In the former case as long as the conjugating diffeomorphisms are sufficiently smooth albeit with huge derivatives fast convergence of the approximations is achieved by conditions like (2.4). Since no control over C^r norms is required it is usually easy to construct C^∞ diffeomorphisms creating an approximate picture required. Of course usually smooth maps can be approximated by real analytic ones. Such maps if they have very large derivatives in the real domain will usually have singularities in a fairly small complex neighborhood of it. But if either a map h or its inverse has complex singularities close to the real domain and S_t , $0 \leq t \leq t_0$, $S_0 = \text{Id}$ is an analytic family then the family $h \circ S_t \circ h^{-1}$ is expected to have singularities close to the real domain for *any* $t > 0$. Thus the domain of analyticity for maps f_n in (2.1) will shrink considerably at any step of the constructions and the limit map f will not be analytic.

There are two possible strategies for overcoming this problem in order to make a version of the approximation by conjugation method work in the real-analytic category.

1. Find conjugacies h_n which are analytic with their inverses in a uniform complex neighborhood of the real domain
2. Compensate singularities of the conjugacies h_n and their inverses in such a way that the maps f_n have a much larger domain of analyticity than the conjugacies.

7.1.1. Uniquely ergodic diffeomorphisms of spheres. The first method has a good chance of working when there is sufficiently large supply of maps commuting with the action \mathbb{S} which can be modified in a controlled way maintaining analyticity in the large domain. This happens for skew products where the S^1 acts in the fibers and in the time-changes of linear flows on the

torus. A less obvious case of this situation was found by the second author [25]. We describe one of the results of that work in a special case.

Consider the standard embedding of the sphere S^{2n-1} into \mathbb{R}^{2n} and the standard complexification $\mathbb{R}^{2n} \subset \mathbb{C}^{2n}$. The vector-field defined in Euclidean coordinates as $v_0(x_1, \dots, x_{2n}) = 2\pi(x_2, -x_1, \dots, x_{2n}, -x_{2n-1})$ defines a linear action $\Phi = \{\varphi^t, t \in \mathbb{R}, \varphi^1 = \text{Id}\}$ of the circle S^1 . In Euclidean coordinates

$$\begin{aligned} \varphi^t(x_1, \dots, x_{2n}) = & (\cos 2\pi t x_1 + \sin 2\pi t x_2, -\sin 2\pi t x_1 + \cos 2\pi t x_2, \dots, \\ & \cos 2\pi t x_{2n-1} + \sin 2\pi t x_{2n}, -\sin 2\pi t x_{2n-1} + \cos 2\pi t x_{2n}). \end{aligned}$$

We will use the same notations v_0 and φ^t for extensions to \mathbb{C}^{2n} or its subsets.

We will call a function on S^{2n-1} *entire* if it extends to a holomorphic function in \mathbb{C}^{2n} . A map $f : S^{2n-1} \rightarrow S^{2n-1}$ is called *entire* if its coordinate functions are entire. A diffeomorphism $f : S^{2n-1} \rightarrow S^{2n-1}$ is entire if both f and f^{-1} are entire maps. Invertible linear maps are obviously entire diffeomorphisms. Notice that product of entire diffeomorphisms is an entire diffeomorphism.

THEOREM 7.1. *For any t_0 , $0 \leq t_0 \leq 1$, $\epsilon > 0$ and any compact set $K \in \mathbb{C}^n$ there exists an entire diffeomorphism $f : S^{2n-1} \rightarrow S^{2n-1}$, preserving Lebesgue measure and uniquely ergodic whose extension to \mathbb{C}^{2n} satisfies*

$$\max\{\max_{z \in K} |f(z) - \varphi^{t_0}(z)|, \max_{z \in K} |f^{-1}(z) - \varphi^{-t_0}(z)|\} \leq \epsilon. \quad (7.1)$$

REMARK 7.2. Notice that while in the C^∞ category the approximation by conjugation method as outlined in Section 2.1 allows to produce a great variety of perturbations of a rotation φ_t with interesting ergodic and topological properties, even minimal real analytic diffeomorphisms of S^3 were not known before.

This result extends to compact Lie groups and some of their homogeneous spaces with an action of S^1 by left translations.

Let us sketch some of the ideas of the proof of Theorem 7.1 in the case of S^3 . There is a natural identification of S^3 with the group $SU(2)$ which identifies Φ with an action by left translations. The space of orbits is naturally identified with S^2 (the Hopf fibration). Right translations on $SU(2)$ act on the factor space as rotations with respect to a natural metric which comes from a bi-invariant metric on $SU(2)$. Neither an individual translation nor a one-parameter group is transitive but of course the whole right action is transitive. Moreover, every right translation also extends to a linear map of \mathbb{C}^4 and is hence entire.

At n th iterative step of the construction one produces an entire diffeomorphism h_n of $S^3 = SU(2)$ which commutes with φ_{1/q_n} . To imitate the uniform distribution in the factor space one uses twisted right translations. First, one fixes a one-parameter subgroup r_t of right translations of $SU(2)$,

or equivalently, an axis of rotation on S^2 . On each orbit \mathcal{O} of this one-parameter group the map h_n is a certain translation $r_{f(\mathcal{O})}$ where the “twisting function” f is entire and is invariant under the left translation φ_{1/q_n} . By making this function sufficiently uniformly distributed mod 1 one achieves a distribution of orbits of the conjugate of Φ (and hence of any of its sufficiently large finite subgroups) which projects to S^2 into a distribution close to the distribution uniform on orbits of r_t . This distribution however is far from uniform. Further approximation is achieved by taking another one-parameter subgroup and averaging the distribution along its orbits. In order to implement this one takes a number $q'_n \gg q_n$ depending on the geometry of the twisting function and constructs another twisting function along the orbits of the new subgroup and invariant with respect to φ_{1/q'_n} , taking the conjugacy as the product of two twisted right translations. This product is still entire and it takes the distribution of orbits of Φ and hence any of its sufficiently large finite subgroups closer to uniform. In fact, in order to achieve almost uniform distribution of *every* orbit one need to either take more than two steps within the inductive step, or choose one-parameters subgroups of right translations at different inductive steps carefully.

REMARK 7.3. This construction produces conjugacies which are far from preserving natural fundamental domains of φ_{1/q_n} . In other words, the choice of h_n is not special in the sense of Section 4.4.4 (See also Section 2.2). This makes controlling subtle ergodic properties of the resulting uniquely ergodic diffeomorphism problematic.

Here is a typical open problem related with this difficulty.

PROBLEM 7.4. Does there exist a real analytic volume preserving diffeomorphism of S^{2n-1} , $n \geq 2$ which is measurably conjugate to an irrational rotation of the circle?

7.1.2. *Exotic holomorphic maps in one complex variable.* The second method requires good understanding of the geometry of special holomorphic maps in the complex domain since just approximating the conjugacies by some standard regular objects even if successful usually produces singularities close to the real domain for inverse maps. In one complex variable there is a sufficient understanding of such special geometry. This allowed R.Perez-Marco and J.-C. Yoccoz [33, 34, 35, 41], developing ideas which originally appeared in Yoccoz’ thesis) to apply approximation by conjugation method and construct analytic circle diffeomorphisms with Liouvillean rotation numbers and exotic properties (e.g. C^∞ but not analytic conjugacy to a rotation).

7.1.3. *Other situations.* Beyond the two cases described above the problem of applicability of the approximation by conjugation scheme of Section 2.1 remains open. This is the case already in the setting of volume preserving diffeomorphisms in dimension two where the majority of examples described in this paper appear. Certain characteristic open problems which appeared already at the time of writing [1] can be summarized as follows.

PROBLEM 7.5. Does there exist an area preserving topologically transitive real analytic diffeomorphism f of the disc \mathbb{D}^2 with either of the following properties:

1. the restriction of f to the boundary is an irrational rotation;
2. f has zero topological entropy;
3. f is C^2 close to the identity?

We finish our discussion of analytic constructions with several comments concerning the above problem.

In the case (1) the rotation number must be Liouvillean; otherwise there are invariant circles as was explained in Section 3.1.

Applicability of the approximation by conjugation method in the analytic setting in the case of manifolds with boundary such as \mathbb{D}^2 depends on our ability to construct real analytic diffeomorphisms of such manifolds with very large derivatives which can be extended together with their inverses to fixed complex neighborhoods. Here is a characteristic question of this kind.

PROBLEM 7.6. Does there exist an $r > 0$ such that for any point $p = (x, y) \in \text{Int } \mathbb{D}^2$ there exists a real analytic area preserving diffeomorphism $f_p : \mathbb{D}^2 \rightarrow \mathbb{D}^2$ which extends together with its inverse to r -neighborhood of \mathbb{D}^2 in the complex domain and such that $f_p(0, 0) = (x, y)$?

Notice that for p close to the boundary such a diffeomorphism f_p must have very large derivatives.

Known examples of real analytic area preserving ergodic (or just topologically transitive) diffeomorphisms of \mathbb{D}^2 are based on modifications on the C^∞ construction first introduced in [23]; see [12] and [31]. Dynamically these examples are non-uniformly hyperbolic, they have positive topological entropy, and with respect to the smooth measure they are Bernoulli (or direct products of Bernoulli with finite permutations). On the boundary these diffeomorphisms are either identity or have rational rotation number with finitely many periodic orbits. Such examples can be made C^1 close to identity (first observed by Michel Herman; private communication) but constructions of this kind are not compatible with C^2 closeness to identity.

7.2. The problem of smooth realization. In its most basic and at the same time general form the smooth realization problem may be formulated as follows;

PROBLEM 7.7 (Smooth realization). Given a measure preserving transformation T of a Lebesgue space (X, μ) does there exist a (C^∞) diffeomorphism f of a compact manifold M preserving a smooth volume ν such that (f, ν) is measurably isomorphic to (T, μ) ?

There are numerous variations and specializations of the problem of which the following is among the most interesting.

PROBLEM 7.8 (Nonstandard smooth realization). Given a diffeomorphism g of a compact manifold N preserving a smooth volume μ and ergodic with

respect to it, does there exist a diffeomorphism f of a compact manifold M preserving a smooth volume ν such that (f, ν) is measurably isomorphic to (g, μ) but not smoothly conjugate to it?

The only known unconditional restriction to smooth realization is finiteness of entropy (see [26, Corollary 3.2.10, Theorem 4.5.3]). In other words, no measure preserving transformation with finite entropy is known not to be realizable on *any* manifold. There are restrictions in low dimension, e.g. any weakly mixing surface diffeomorphism is Bernoulli.

The approximation by conjugation method provides instances of both nonstandard smooth realization of certain diffeomorphisms and smooth realization of maps whose original description is not smooth. This included nonstandard smooth realization of rotations with some Liouvillean rotation numbers discussed above in 2.4.2 (See [1, Section 4]; this was recently improved to any Liouvillean rotation number [36]). Very likely these methods should allow nonstandard realization of some Diophantine rotations by diffeomorphisms of finite differentiability. It looks though that the following problem tests the limits of power of the approximation by conjugation method and most likely requires new ideas.

PROBLEM 7.9. Does there exist a nonstandard smooth realization of a Diophantine rotation of the circle by a C^∞ diffeomorphism?

Such a diffeomorphism must act on a manifold of dimension at least two.

In [1, Section 6] nonstandard smooth realizations of certain translations on tori were constructed, as well as smooth realizations of certain rotations on the infinite dimensional torus. The latter was the earliest example of smooth realization of a transformation whose natural “habitat” is not a finite dimensional manifold. In [24, Section 8] a general setting is described which allows (with further specification of parameters) smooth realization of transformations belonging to measurable combinatorial constructions. Let us list several characteristic problems which in our view can be approached by a version of the approximation by conjugation method or its modification with decreasing chances of success.

PROBLEM 7.10. Find a smooth realization of:

1. a Gaussian dynamical system with simple (Kronecker) spectrum;
2. a dense G_δ set of minimal interval exchange transformations;
3. an adding machine;
4. the time-one map of the horocycle flow 2.3.1 on the modular surface $SO(2)\backslash SL(2, \mathbb{R})/SL(2, \mathbb{Z})$ (which is not compact, so the standard realization cannot be used).

A version of the smooth realization problem addresses possibility of obtaining certain properties invariant under measurable conjugacy for volume preserving diffeomorphisms of compact manifolds. In particular one may ask about properties which are generic for measure preserving transformations in weak topology (which are also then generic for volume preserving

homeomorphisms in C^0 topology). While such properties cannot be generic in C^r smooth topology by reasons quite different for $r = 1$ and $r \geq 2$, one can consider spaces of closures of conjugacies as in Section 2.3 and try to determine whether generic properties of measure preserving diffeomorphisms can be realized there or are generic in those spaces which we denote by \mathcal{A} with various indexes. It seems that the notion of periodic approximation of a given type in the sense of [24, Definition 1.9] is quite useful in this respect. Since approximation of any type with any (arbitrary fast) speed is generic in weak topology [24, Theorem 2.1] any property which follows from any finite or countable combination of approximation type properties is generic too. Cyclic approximation where approximating periodic processes have a single tower is generic in the space \mathcal{A} and certain types of homogeneous approximation where there may be many towers but their heights are all equal [24, Section 5] can be shown to be generic too. However periodic processes with towers of unequal height such as type $(n, n + 1)$ approximations with two towers whose heights differ by one do not naturally appear in the conjugacies of elements of S^1 actions. Those approximations and their generalizations are useful in establishing genericity of various properties (see e.g. [24, Section 3.3]). It looks likely that in the case of actions of \mathbb{T}^k , $k \geq 2$ it may be easier to produce these types of approximation in the closure of conjugacies.

PROBLEM 7.11. Given a circle action \mathcal{S} and the corresponding space \mathcal{A} is there a diffeomorphism $f \in \mathcal{A}$ with either of the following properties:

1. good approximation of type $(n, n + 1)$;
2. maximal spectral type disjoint with its convolutions;
3. homogeneous spectrum of multiplicity two for the Cartesian square $f \times f$?

See [24, Sections 3,4] for relevant definitions and results.

PROBLEM 7.12. Is existence of a measurable square root (or roots of all orders) generic in \mathcal{A} ? (Cf. [28]).

REMARK 7.13. Notice that unlike the previous problem existence is known here because for example any rotation of the circle has roots of all orders and there are diffeomorphisms measurably isomorphic to rotations [1, section 4].

Given an action \mathcal{T} of \mathbb{T}^2 denote the closure of conjugacies of elements of this action in the C^∞ topology by \mathcal{B} .

PROBLEM 7.14. Is there a diffeomorphism $f \in \mathcal{B}$ with either of the following properties:

1. good approximation of type $(n, n + 1)$;
2. maximal spectral type disjoint with its convolutions;
3. homogeneous spectrum of multiplicity two for the Cartesian square $f \times f$;
4. mixing?

Positive answer to the last question will be of course a discrete time version of Theorem 6.1. It looks very likely to be true.

REFERENCES

- [1] D.V. Anosov and A.B. Katok, New examples in smooth ergodic theory. Ergodic diffeomorphisms, Trans. Moscow Math. Soc. 23 (1970), 1-35.
- [2] A.S. Besicovitch, A problem on topological transformations of the plane. II. Proc. Cambridge Philos. Soc. 47, (1951). 38–45.
- [3] I.U. Bronstein, Extensions of minimal transformation groups. Translated from the Russian. Martinus Nijhoff Publishers, The Hague, 1979.
- [4] P. Le Calvez and J.-C. Yoccoz, Un théorème d'indice pour les homéomorphismes du plan au voisinage d'un point fixe, Ann. of Math. (2) 146 (1997), no. 2, 241–293.
- [5] A. Fathi and M.R. Herman Existence de difféomorphismes minimaux. (French) Dynamical systems, Vol. I—Warsaw, pp. 37–59. Asterisque, No. 49, Soc. Math. France, Paris, 1977.
- [6] B. Fayad, Analytic mixing reparametrizations of irrational flows. Ergodic Theory Dynam. Systems 22 (2002), no. 2, 437–468.
- [7] B. Fayad, Skew products over translations on T^d , $d \geq 2$. Proc. Amer. Math. Soc. 130 (2002), no. 1, 103–109.
- [8] B. Fayad, Weak mixing for reparameterized linear flows on the torus. Ergodic Theory Dynam. Systems 22 (2002), no. 1, 187–201.
- [9] B. Fayad, Topologically mixing and minimal but not ergodic, analytic transformation on T^5 . Bol. Soc. Brasil. Mat. (N.S.) 31 (2000), no. 3, 277–285.
- [10] B. Fayad, Topologically mixing flows with pure point spectrum, to appear.
- [11] B. Fayad, R. Krikorian, M. Saprikina, Ergodic properties of disc diffeomorphisms and their rotation number on the boundary, Preprint.
- [12] M. Gerber, Conditional stability and real analytic pseudo-Anosov maps. Mem. Amer. Math. Soc. 54 (1985), no. 321.
- [13] H. Furstenberg, Strict ergodicity and transformation of the torus. Amer. J. Math. 83 1961 573–601.
- [14] R. Gunesch and A. Katok, Construction of weakly mixing diffeomorphisms preserving measurable Riemannian metric and smooth measure. With an appendix by Alex Furman. Discrete Contin. Dynam. Systems 6 (2000), no. 1, 61–88.
- [15] M. Handel, A pathological area preserving C^∞ diffeomorphism of the plane. Proc. Amer. Math. Soc. 86 (1982), no. 1, 163–168.
- [16] B. Hasselblatt and A. Katok, Principal structures, Handbook in Dynamical Systems, vol 1A Elsevier, 2002, 1–203.
- [17] M. Herman, Sur la conjugaison différentiable des difféomorphismes du cercle à des rotations. (French) Inst. Hautes Etudes Sci. Publ. Math. No. 49 (1979), 5–233.
- [18] M. Herman Sur les courbes invariantes par les difféomorphismes de l'anneau. (French) ; Vol 1, Astérisque, 103-104. Société Mathématique de France, Paris, 1983; Vol 2. Astérisque, 144, 1986.
- [19] M. Herman, Construction of some curious diffeomorphisms of the Riemann sphere. J. London Math. Soc. (2) 34 (1986), no. 2, 375–384.
- [20] M. Herman On the dynamics of Lagrangian tori invariant by symplectic diffeomorphisms. Progress in variational methods in Hamiltonian systems and elliptic equations (L'Aquila, 1990), 92–112, Pitman Res. Notes Math. Ser., 243, Longman Sci. Tech., Harlow, 1992.
- [21] M. Herman Some open problems in dynamical systems. Proceedings of the International Congress of Mathematicians, Vol. II (Berlin, 1998). Doc. Math. 1998, Extra Vol. II, 797–808

- [22] A.B. Katok, Minimal diffeomorphisms on principal S^1 -bundles (Russian), abstracts of 6 All-Union Topological Conference, Tbilisy, 1972, 63.
- [23] A. Katok, Bernoulli diffeomorphisms on surfaces, *Ann. of Math.* (2) 110 (1979), no. 3, 529–547.
- [24] A. Katok, Combinatorial constructions in ergodic theory and dynamics, AMS, Providence R.I., to appear.
- [25] A. Katok, Analytic minimal and uniquely ergodic diffeomorphisms, in preparation.
- [26] A. Katok and B. Hasselblatt, Introduction to the modern theory of dynamical systems, *Encyclopedia of Mathematics and its Applications*, 54. Cambridge University Press, Cambridge, 1995.
- [27] A.B. Katok and A.M. Stepin, Approximations in ergodic theory, *Russian Math. Surveys*, 22, No.5 (1967), 77–102.
- [28] J. King, The generic transformation has roots of all orders. *Colloq. Math.* 84/85 (2000), part 2, 521–547.
- [29] D. Kleinbock, N. Shah, and A. Starkov, Dynamics of subgroup actions on homogeneous spaces of Lie groups and applications to number theory, *Handbook in Dynamical Systems*, vol 1A Elsevier, 2002, 813–930.
- [30] A.V. Kočergin, Nondegenerate saddles and the absence of mixing, *Math. Notes USSR Acad. Sci* 19 (1976) no 3, 277–286.
- [31] J. Lewowicz and E. Lima de Sa, Analytic models of pseudo-Anosov maps. *Ergodic Theory Dynam. Systems* 6 (1986), no. 3, 385–392.
- [32] J. Moser, On the volume elements on a manifold, *Trans. Amer. Math. Soc.* 120 (1965), 286–294
- [33] R. Perez-Marco, Sur les dynamiques holomorphes non linéarisables et une conjecture de V. I. Arnol'd. (French) *Ann. Sci. École Norm. Sup.* (4) 26 (1993), no. 5, 565–644.
- [34] R. Perez-Marco, Nonlinearizable holomorphic dynamics having an uncountable number of symmetries. *Invent. Math.* 119 (1995), no. 1, 67–127.
- [35] R. Perez-Marco, Siegel disks with smooth boundary, Preprint.
- [36] M. Saprykina, A. Windsor,
- [37] L.G. Shnirelman, An example of a transformation of the plane (Russian), *Proc. Don Polytechnic Inst (Novochekassk)*, 14, Science section, Fis-math. part (1930), 64–74
- [38] A. Windsor, Minimal but not uniquely ergodic diffeomorphisms. *Smooth ergodic theory and its applications* (Seattle, WA, 1999), 809–824, *Proc. Sympos. Pure Math.*, 69, Amer. Math. Soc., Providence, RI, 2001.
- [39] J.-C. Yoccoz, Conjugaison différentiable des difféomorphismes du cercle dont le nombre de rotation vérifie une condition diophantienne. (French) *Ann. Sci. École Norm. Sup.* (4) 17 (1984), no. 3, 333–359.
- [40] J.-C. Yoccoz, Centralisateurs et conjugaison différentiable des difféomorphismes du cercle. (French) *Petits diviseurs en dimension 1. Astérisque*, 231 (1995), 89–242.
- [41] J.-C. Yoccoz, Analytic linearization of circle diffeomorphisms. *Dynamical systems and small divisors* (Cetraro, 1998), *Lecture Notes in Math.*, 1784, Springer, Berlin, 2002, 125–173.

BASSAM FAYAD, UNIVERSITÉ PARIS 13, CNRS 7539, VILLETANEUVE 93430

E-mail address: fayadb@math.univ-paris13.fr

ANATOLE KATOK, DEPARTMENT OF MATHEMATICS, PENN STATE UNIVERSITY, STATE COLLEGE, PA 16802

E-mail address: katok_a@math.psu.edu